

Instruction Manual

XLG/XLF SERIES

High Voltage Power Supply

MODEL :
SERIAL# :
DATE :

**SPELLMAN
HIGH VOLTAGE ELECTRONICS
CORPORATION**

475 Wireless Blvd.
Hauppauge, New York, 11788

+1(631) 630-3000*FAX: +1(631) 435-1620*

E-mail: sales@spellmanhv.com

Website: www.spellmanhv.com



- **OUTPUT VOLTAGES TO 130KV**
- **INTEGRATED GROUND REFERENCED FILAMENT SUPPLY**
- **LOW RIPPLE**
- **“HOT ANODE”**
- **POSITIVE POLARITY**
- **LOCAL & REMOTE PROGRAMMING**
- **OEM CUSTOMIZATION AVAILABLE**

www.spellmanhv.com/manuals/XLG

Spellman's XLG Series of X-ray generators are well regulated high voltage power supplies with output voltages to 130kV and very low ripple achieved through the use of advanced resonant conversion techniques. Extremely stable voltage and emission current outputs result in significant performance improvements over previously available technology. The XLG Series provides all the power, control and support functions required for X-ray applications including a regulated dc filament supply. These units incorporate local and remote programming, monitoring, safety interlock, short-circuit and overload protection.

TYPICAL APPLICATIONS

- Plating Measurement
- Mineral Analysis
- X-ray Fluorescence

OPTIONS

- APT** Adjustable Power Trip
- AT** Arc Trip
- SS(x)** Non-Standard Slow Start
- NSS** No Slow Start
- IO** Instant ON
- LL(x)** Extra Length HV Cable
- SL** Slides

SPECIFICATIONS

Input Voltage:

115Vac±10%, 50-60Hz single phase or
220Vac±10%, 50-60Hz single phase.

Voltage and Current Control:

Local: continuously adjustable from zero to maximum rating via a ten-turn potentiometer with a lockable counting dial.

Remote: 0 to +10Vdc proportional from 0 to full output.
Accuracy: ±1%. Input Impedance: 10Mohm.

Filament:

Specify at time of order:
FH: 9A, 3V.
FL: 3A, 3V.
Preheat level is 0.45 amps in standby

Voltage Regulation:

Load: 0.005% of full output voltage no load to full load.
Line: 0.005% for input voltage range change.

Current Regulation:

Load: 0.05% of full current ±100µA from 0 to full voltage.
Line: 0.05% of rated current over specified input range.

Ripple:

0.03% rms below 1kHz.
0.75% rms above 1kHz.

Temperature Coefficient:

100ppm/°C.

Stability:

0.01%/8 hrs after 1/2 hour warm-up.
0.02% per 8 hours (typical).

Cooling:

Free air convection.

Metering:

Digital voltage and current meters (3.5 digits),
1% accuracy.

HV Output Cable:

10' (3.3m) of shielded HV cable removable at rear.

I/O Connectors:

25 pin D-type for control interface with mating connector provided.

Dimensions:

30 to 60kV:
3.5"H x 19"W x 19"D (8.9cm x 48.3cm x 48.3cm).
80 to 130kV:
3.5"H x 19"W x 24"D (8.9cm x 48.3cm x 61.0cm).

Regulatory Approvals:

Compliant to 2004/108/EC, the EMC Directive
and 2006/95/EC, the Low Voltage Directive.

FRONT PANEL STATUS INDICATORS:

- | | |
|------------------|----------------------|
| Overvoltage | Voltage Control Mode |
| Overtemperature | Current Control Mode |
| Regulation Error | Interlock Open |
| Arc | Interlock Closed |
| HV ON: Red | HV OFF: Green |

XLG SELECTION TABLE 0.1mA, 0.2mA , 0.5mA

kV	0.1mA	0.2mA	.5mA
30	XLG30P3*	XLG30P6*	XLG30P15*
35	XLG35P3.5*	XLG35P7*	XLG35P17.5*
40	XLG40P4*	XLG40P8*	XLG40P20*
50	XLG50P5*	XLG50P10*	XLG50P25*
60	XLG60P6*	XLG60P12*	XLG60P30*
80	XLG80P8*	XLG80P16*	XLG80P40*
100	XLG100P10*	XLG100P20*	XLG100P50*
120	XLG120P12*	XLG120P24*	XLG120P60*
130	XLG130P13*	XLG130P26*	XLG130P65*

*Specify FH for High power (27W) filament, FL for Low power (9W) filament.

XLG SELECTION TABLE 1.0mA, 2.0mA, 3.0mA

kV	1.0mA	2.0mA	3.0mA
30	XLG30P30*	XLG30P60*	XLG30P90*
35	XLG35P35*	XLG35P70*	XLG35P105*
40	XLG40P40*	XLG40P80*	XLG40P120*
50	XLG50P50*	XLG50P100*	XLG50P150*
60	XLG60P60*	XLG60P120*	XLG60P180*
80	XLG80P80*	XLG80P160*	---
100	XLG100P100*	XLG100P200*	---
120	XLG120P120*	XLG120P240*	---
130	XLG130P130*	XLG130P260*	---

*Specify FH for High power (27W) filament, FL for Low power (9W) filament.

XLG CONNECTOR 25 PIN

JB1	SIGNAL	SIGNAL PARAMETERS
1	Power Supply Common	Signal Ground
2	External Inhibit	Ground=Inhibit, Open=HV On
3	External Interlock	+15V at Open, <15mA at Closed
4	External Interlock Return	Return for Interlock
5	Current Monitor	0 to 10V=0 to 100% Rated Output
6	kV Test Point	0 to 10V=0 to 100% Rated Output
7	+10V Reference	+10V, 1mA Max
8	Remote Current Program In	0 to 10V=0 to 100% Rated Output
9	Local Current Program Out	Front Panel Program Voltage
10	Remote Voltage Program In	0 to 10V=0 to 100% Rated Output
11	Local Voltage Program Out	Front Panel Program Voltage
12	Power Monitor	0 to 10V=0 to 100% Rated Output
13	Remote Power Program In	(Optional)
14	Local HV Off Out	+15V at Open, <25mA at Closed
15	HV Off	Connect to HV OFF for Fp Operation
16	Remote HV On	+15V, 10mA Max=HV Off
17	Remote HV Off Indicator	0=HV On, +15V, 10mA Max=HV Off
18	Remote HV On Indicator	0=HV Off, +15V, 10mA Max=HV On
19	Remote Voltage Mode	
20	Remote Current Mode	Open Collector 50V Max, 10mA Max
21	Remote Power Mode	On=Active
22	Remote PS Fault	0=Fault, +15V, 0.1mA Max=No Fault
23	+15V Output	+15V, 100mA Max
24	Power Supply Common	Signal Ground
25	Shield Return	Shield Return

DIMENSIONS: in.[mm]

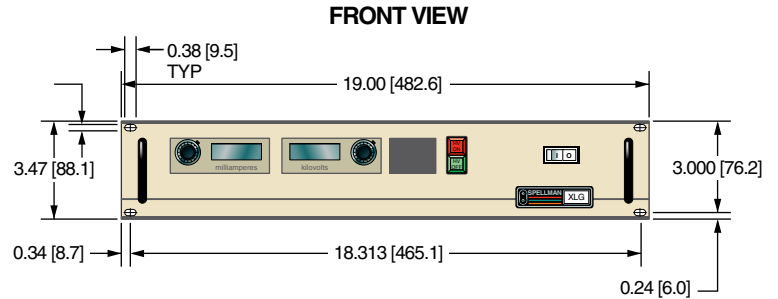

TOP VIEW

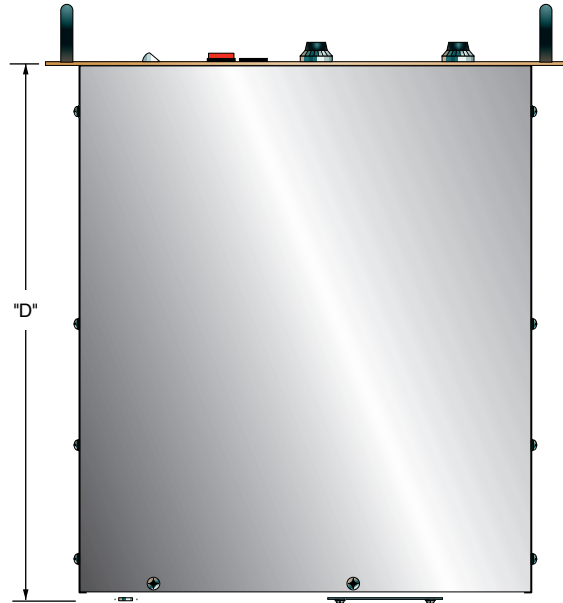

BACK VIEW

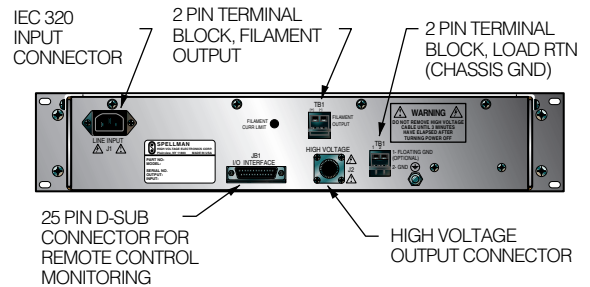

IMPORTANT SAFETY PRECAUTIONS

SAFETY

THIS POWER SUPPLY GENERATES VOLTAGES THAT ARE DANGEROUS AND MAY BE FATAL.
OBSERVE EXTREME CAUTION WHEN WORKING WITH THIS EQUIPMENT.

High voltage power supplies must always be grounded.

Do not touch connections unless the equipment is off and the Capacitance of both the load and power supply is discharged.

Allow five minutes for discharge of internal capacitance of the power supply.

Do not ground yourself or work under wet or damp conditions.

SERVICING SAFETY

Maintenance may require removing the instrument cover with the power on.

Servicing should be done by qualified personnel aware of the electrical hazards.

WARNING note in the text call attention to hazards in operation of these units that could lead to possible injury or death.

CAUTION notes in the text indicate procedures to be followed to avoid possible damage to equipment.

Copyright © 2000, Spellman High Voltage Electronics Corporation. All Rights Reserved.
This information contained in this publication is derived in part from proprietary and patent data. This information has been prepared for the express purpose of assisting operating and maintenance personnel in the efficient use of the model described herein, and publication of this information does not convey any right to reproduce it or to use it for any purpose other than in connection with installation, operation, and maintenance of the equipment described.

WICHTIGE SICHERHEITSHINWEISE

SICHERHEIT

DIESES HOCHSPANNUNGSNETZTEIL ERZEUGT LEBENSGEFÄHRLICHE HOCHSPANNUNG.
SEIN SIE SEHR VORSICHTIG BEI DER ARBEIT MIT DIESEM GERÄT.

Das Hochspannungsnetzteil muß immer geerdet sein.

Berühren Sie die Stecker des Netzteiles nur, wenn das Gerät ausgeschaltet ist und die elektrischen Kapazitäten des Netzteiles und der angeschlossenen Last entladen sind.

Die internen Kapazitäten des Hochspannungsnetzteiles benötigen ca. 5 Minuten, um sich zu entladen.

Erden Sie sich nicht, und arbeiten Sie nicht in feuchter oder nasser Umgebung.

SERVICESICHERHEIT

Notwendige Reparaturen können es erforderlich machen, den Gehäusedeckel während des Betriebes zu entfernen.

Reparaturen dürfen nur von qualifiziertem, eingewiesenem Personal ausgeführt werden.

“WARNING” im folgenden Text weist auf gefährliche Operationen hin, die zu Verletzungen oder zum Tod führen können.

“CAUTION” im folgenden Text weist auf Prozeduren hin, die genauestens befolgt werden müssen, um eventuelle Beschädigungen des Gerätes zu vermeiden.

PRECAUTIONS IMPORTANTES POUR VOTRE SECURITE

CONSIGNES DE SÉCURITÉ

CETTE ALIMENTATION GÉNÈRE DES TENSIONS QUI SONT DANGEUREUSES ET PEUVENT ÊTRE FATALES.
SOYEZ EXTRÊMEMENT VIGILANTS LORSQUE VOUS UTILISEZ CET ÉQUIPEMENT.

Les alimentations haute tension doivent toujours être mises à la masse.

Ne touchez pas les connectiques sans que l'équipement soit éteint et que la capacité à la fois de la charge et de l'alimentation soient déchargées.

Prévoyez 5 minutes pour la décharge de la capacité interne de l'alimentation.

Ne vous mettez pas à la masse, ou ne travaillez pas sous conditions mouillées ou humides.

CONSIGNES DE SÉCURITÉ EN CAS DE REPARATION

La maintenance peut nécessiter l'enlèvement du couvercle lorsque l'alimentation est encore allumée.

Les réparations doivent être effectuées par une personne qualifiée et connaissant les risques électriques.

Dans le manuel, les notes marquées « **WARNING** » attire l'attention sur les risques lors de la manipulation de ces équipements, qui peuvent entraîner de possibles blessures voire la mort.

Dans le manuel, les notes marquées « **CAUTION** » indiquent les procédures qui doivent être suivies afin d'éviter d'éventuels dommages sur l'équipement.

IMPORTANTI PRECAUZIONI DI SICUREZZA

SICUREZZA

QUESTO ALIMENTATORE GENERA TENSIONI CHE SONO PERICOLOSE E POTREBBERO ESSERE MORTALI.
PONI ESTREMA CAUTELA QUANDO OPERI CON QUESTO APPARECCHIO.

- Gli alimentatori ad alta tensione devono sempre essere collegati ad un impianto di terra.
- Non toccare le connessioni a meno che l'apparecchio sia stato spento e la capacità interna del carico e dell'alimentatore stesso siano scariche.
- Attendere cinque minuti per permettere la scarica della capacità interna dell'alimentatore ad alta tensione.
- Non mettere a terra il proprio corpo oppure operare in ambienti bagnati o saturi d'umidità.

SICUREZZA NELLA MANUTENZIONE.

- Manutenzione potrebbe essere richiesta, rimuovendo la copertura con apparecchio acceso.
- La manutenzione deve essere svolta da personale qualificato, coscio dei rischi elettrici.
- Attenzione alle **AVVERTENZE** contenute nel manuale, che richiamano all'attenzione ai rischi quando si opera con tali unità e che potrebbero causare possibili ferite o morte.
- Le note di **CAUTELA** contenute nel manuale, indicano le procedure da seguire per evitare possibili danni all'apparecchio.

Table of Contents

	PAGE
1. INTRODUCTION	
1.1 Description of the XLG/XLF Series	1
1.2 XLG/XLF Specifications	1
1.3 Standard Features	2
1.3.1 Remote Operating Features	2
1.3.2 System Status and Fault Diagnostic Display	2
1.4 Options	3
1.5 Interpreting the Model Number	3
2. INSPECTION & INSTALLATION	
2.1 Initial Inspection	4
2.2 Mechanical Installation	4
3. OPERATING INSTRUCTIONS	
3.1 Operation	6
3.2 Standard Features	6
4. PRINCIPLES OF OPERATION	
4.1 Chassis	16
4.2 Line Rectifier and Filtering	16
4.3 Inverter	17
4.4 High Voltage Transformer	17
4.5 High Voltage Assembly	17
4.6 Control/Power PWB	17
4.7 Front Panel Assembly	18
4.8 Filament Supply PWB	18
4.9 Options	18
5. OPTIONS	
5.1 Adjusting Overload Trip	19
5.2 220C AC Single Phase Input	19
5.3 No Slow Start	19
5.4 Non-Standard Slow Start	19
5.5 Extra Length Output Cable	19
5.6 Adjustable Power Trip	19
5.7 Arc Trip Option	19
5.8 Instant ON Option	19
5.9 Custom Designed Models	19

6. MAINTENANCE	
6.1	Periodic Servicing.....21
6.2	Performance Test21
6.3	High Voltage Dividers21
7. REPLACEMENT PARTS	
7.1	Replacement Parts.....22
7.2	Correspondence and Ordering Spare Parts22
8. FACTORY SERVICE	
8.1	Warranty Repairs23
8.2	Factory Service Procedures23
8.3	Ordering Options and Modifications23
8.4	Shipping Instructions23

APPENDIX

- A. Specification Controls (Custom Models Only)
- B. Schematics

LIST OF FIGURES

Figure 2.1	Dimensions XLG and XLF.....5
Figure 3.1	Typical Operating Setup XLG8
Figure 3.2	Typical Operating Setup XLF.....9
Figure 3.3A	Remote Programming Via Voltage Source.....11
Figure 3.3B	Remote Programming Via External Resistance.....11
Figure 3.4	Remote Monitor Test Point Designations.....12
Figure 3.5	Remote Control of HV ON and HV OFF12
Figure 3.6	External Inhibit Interface Circuit.....13
Figure 3.7	External Interlock Interface Circuit13
Figure 3.8	Remote HV ON and Remote HV OFF Indicator Circuit.....14
Figure 3.9	Remote Mode Indicators Interface15
Figure 5.1	Instant ON Option.....20
Figure 5.2	Adjustable Power Remote Interface20

LIST OF TABLES

Table 1.1	Options.....3
Table 3.1	Rear Panel Interface.....10
Table 4.1	List of Main Assemblies17

Chapter 1

INTRODUCTION

1.1 Description Of The XLG/XLF Series

The XLG/XLF series of high voltage power supplies represent an advanced approach to X-ray generator power requirements. These power supplies provide all of the power, control, and support functions required for practically all X-ray applications. The XLG/XLF series provide high voltage, high current outputs with very low ripple. Extremely stable voltage and current outputs result in significant performance improvements over previously available technology. Low output ripple provides higher intensity levels, with no increase in tube loading.

All these advancements are possible only by Spellman's long history in X-ray power systems. These series of power supplies utilize extremely advanced resonant conversion techniques, along with sophisticated digital technology.

The XLF series is specifically designed for X-ray tube application where the high voltage is a negative polarity, and the filament circuits are referenced to the cathode high voltage potential, (floating filament). The XLG series is specifically designed for X-ray tube applications where the high voltage is a positive polarity, and the filament circuits are referenced to cathode ground potential, (grounded filament).

The X-ray tube voltage and tube emission current are all continuously adjustable via front panel and/or remote controls.

The power supplies operate from a variety of line voltages and are convection cooled for 1 – 300W models and fan cooled for 800 to 1200W models requiring no water cooling. Custom designed units for single use or OEM applications are available.

1.2 XLG/XLF Specifications

- **Output Control:** Voltage and current are continuously adjustable over the entire range from zero to maximum rating a ten-turn potentiometer with a lockable counting dial.
- **Input Voltage:** 115Volts AC \pm 10%, 50/60Hz, single phase or 220Volts AC \pm 10%, 50/60Hz, single phase. 1200W models are available with 220 V AC input

only. Specify input voltage at time of order. Other line voltages are available.

- **Voltage Regulation:**
 - Load Regulation:** 0.005% of full voltage for a no load to full load change.
 - Line Regulation:** 0.005% of full voltage over the specified input voltage range.
- **Current Regulation:**
 - Load Regulation:** 0.05% \pm of full current \pm 100uA for any voltage change.
 - Line Regulation:** \pm 0.01% of full current over the specified input voltage range.
- **Ripple:** 0.03%rms below 1kHz,
0.75%rms above 1kHz.
- **Filament XLG:**
 - HPWR: 9A, 3V
 - LPWR: 3A, 3V
- **Filament XLF:** 5A, 15V.
- **Stability:** 0.01% per hour after 1/2 hour warm up. 0.02% per 8 hours (typical).
- **Temperature Coefficient:** 100 ppm per $^{\circ}$ C. Higher stability (50 ppm per $^{\circ}$ C) available on special order.
- **Ambient Temperature:**
 - Operating: 0 $^{\circ}$ C to +40 $^{\circ}$ C
 - Storage: -40 $^{\circ}$ C to +85 $^{\circ}$ C
- **Metering:** Digital voltage and current meters are accurate to 1%.
- **Weight:** 17 to 30 lbs. (7.7 to 14kg) depending on model.
- **Physical:**
 - XLG:**
 - 30-60kV: 3 1/2"H x 19"W x 19"D rack mount. (89 x 483 x 483mm).
 - 80-130V: 3 1/2"H x 19"W x 19"D rack mount. (89 x 483 x 483mm).
 - XLF:**
 - 3 1/2"H x 19"W x 20"D rack mount. (89 x 483 x 508mm).

1.3 Standard Features

The XLG/XLF series incorporates several standard features designed to optimize user satisfaction and safety.

KV AND MA/FILAMENT CURRENT RAMP CIRCUITS: This feature provides for a gradual rise for kV, mA and filament current. This feature is designed to limit voltage shock and filament shock to the X-ray tube. The kV ramp rate is approximately 6 seconds. The filament current is slowly increased until the desired mA level is achieved. This time is typically 5 seconds for full mA output. These ramp conditions are started at the initial HV ON control signal.

ARC DETECT / ARC QUENCH / ARC COUNT: These features allow the user to tailor the power supply to meet specific needs in dynamic load applications. If an arc occurs, the output is inhibited for approximately one second, then the output is ramped up to the preset level with the Slow-start circuitry. See Chapter 3 for operating details and information for user customization for these features.

INTERNAL FAULT PROTECTION: The XLG/XLF series continually monitors internal circuits critical to the proper operation of the power supply. In the event that one of these circuits does not function correctly, the fault detection circuit latches the appropriate fault on the front panel display and turns off the outputs and reverts the unit to the POWER DOWN mode.

INDICATOR LAMPS: HIGH VOLTAGE OFF and HIGH VOLTAGE ON indicators.

OUTPUT CABLE: XLG models are provided with a ten foot shielded high voltage output cable. The cables are designed with a plug arrangement so that they can be easily removed from the mating receptacle located on the rear of the chassis. internal EMI filter and fuse provide protection against line voltage surges and power supply faults.

1.3.1 Remote Operating Features

REMOTE PROGRAMMING: Allows remote adjustment of the output voltage and current via an external voltage source. The output power is also remotely controllable when the CPC or APT option is ordered.

REMOTE MONITOR: Allows remote monitoring of the tube voltage and tube emission current. NOTE: Output power remote monitor is included with the CPC and APT options.

REMOTE HIGH VOLTAGE CONTROL: Allows remote control of the HIGH VOLTAGE ON and HIGH VOLTAGE OFF functions. Signals are also provided for remote indication of HV ON or HV OFF status.

EXTERNAL INHIBIT: A circuit that will inhibit the high voltage output is provided of the 25 pin mini-D connector on the rear of the chassis. A logic low, ground, will inhibit the high voltage output and a logic high, open, will restore the high voltage output to the preset level.

NOTE: The External Inhibit circuit should NOT be used for protection against injury or for safety interlock. See External Interlock for this type of safety control

EXTERNAL INTERLOCK: Interlock connections are provided on the terminal block on the rear of the chassis for connection to a safety switch. The unit will not operate unless the interlock circuit is closed. During high voltage operation, opening the interlock circuit will cause the High Voltage to shut off. This circuit should be used for safety interlock circuits.

1.3.2 System Status and Fault Diagnostic Display

“Dead Front” type indicators are provided to give the user complete indication of system operation and fault conditions. If a fault occurs the power supply will revert to the POWER DOWN mode. This is indicated by both the HV ON and HV OFF lamps turning off. To reset, depress the HV OFF switch.

VOLTAGE (CONTROL): Indicates the output voltage regulator circuit is maintaining voltage regulation.

CURRENT (CONTROL): Indicates the output current regulator circuit is maintaining current regulation.

POWER (CONTROL): Indicates the output power regulator circuit is limiting tube power (optional).

HV INHIBIT: Indicates the high voltage supply is being inhibited by either the EXTERNAL INHIBIT or internal protection circuitry.

INTLK CLSD: Indicates the EXTERNAL INTERLOCK connections are in the closed position. This also indicates closure of internal power supply interlocks.

INTLK OPEN: Indicates the EXTERNAL INTERLOCK connections are in the open position. This also indicates opening of internal power supply interlocks.

OVERVOLT: Indicates the overvoltage protection circuitry has caused the power supply to turn off. Overvoltage protection is internally set to 110% of rated output voltage.

OVERCURR: Indicates the output current has exceeded the programmed current trip level when the AOL (Adjustable Overload Trip) or the OL (overload Trip) options are installed.

OVERPWR: Indicates the output power has exceeded the internally set level or the remote programmed level if the optional circuitry is installed.

ARC: Indicates that an arc has occurred within the previous one second or that the ARC COUNT/TRIP has shutdown the power supply.

RGLT ERR: Indicates a failure in the voltage, current or power regulation circuitry. This fault usually occurs when there is a lack of output power to maintain regulation.

FILAMENT STANDBY/LIMIT (rear panel): Indicates the filament is in a standby or limit mode. Also, when illuminated, this indicates the emission current regulator is not regulating.

1.4 Options

CODE DISCRIPTION	
• AOL	Adjustable Overload Trip (0-103%)
• APT	Adjustable Power Trip
• AT	Arc Trip
• SS(X)	Non-Standard Slow Start
• NSS	No Slow Start
• IO	Instant ON
• ()	Specify 220V or 100V or 200Vac Single Phase input with order
• DPM4	4 ½ digit ±1 least significant digit panel mrt
• LL(X)	Extra Length Output Cable
• SL	Slides
• BFP	Blank Front Panel

Table 1.1 XLG/XLF Options

The options available are listed in Table 1.1. See Section 5 for more information on these options along with operating and set-up instructions. With few exceptions, these options and modifications can be retrofitted to your power supply at the factory in a short time. For price and retrofit arrangements, contact Spellman's Sales Department.

1.5 Interpreting the Model Number:

The model number of the power supply describes its capabilities. After the series name is:

- (1) the maximum voltage (in kV)
- (2) the maximum output (in watts)
- (3) the option codes for all options that are included.

Custom units have an X number after the option codes.

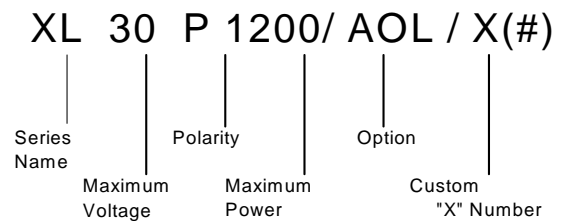

Chapter 2

Inspection and Installation

Initial inspection and preliminary checkout procedures are recommended. For safe operation, please follow the step-by-step procedures described in Chapter 3, Operating Instructions.

2.1 Initial Inspection

Inspect the package exterior for evidence of damage due to handling in transit. Notify the carrier and Spellman immediately if damage is evident. Do not destroy or remove any of the packing material used in a damaged shipment.

After unpacking, inspect the panel and chassis for visible damage.

Fill out and mail the Warranty Registration card accompanying the unit. Standard Spellman XLG/XLF high voltage power supplies and

components are covered by warranty. Custom and special order models (with an X suffix in the model number) are also covered by warranty.

2.2 Mechanical Installation

Units in the XLG/XLF series have front panel holes for standard EIA rack mounting. The rack must allow rear access for cable connections. Units are fully enclosed and are suitable for bench or tabletop operation. Standard unit dimensions are shown in Figure 2.1. It is strongly recommended to support the chassis by guides or slides. Slides are available for ease of servicing (SL option).

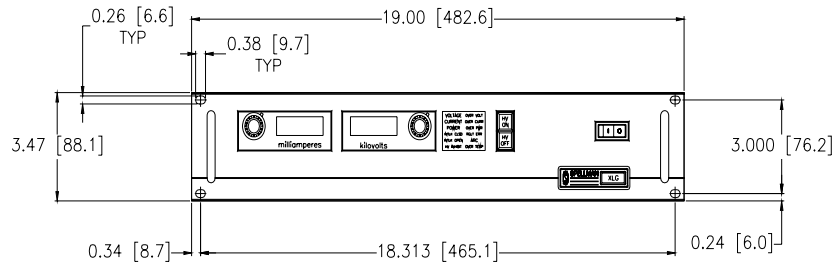

FRONT PANEL

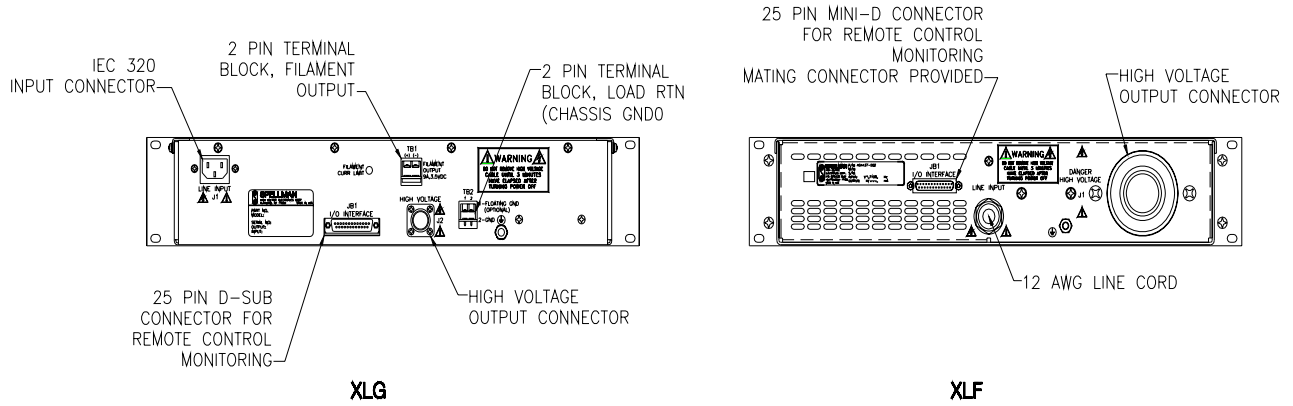

CONFIGURATION	"L"
XLG, 30-60kV	19" [482.6]
XLG, 80-130kV	24" [609.6]
XLF	20" [508]

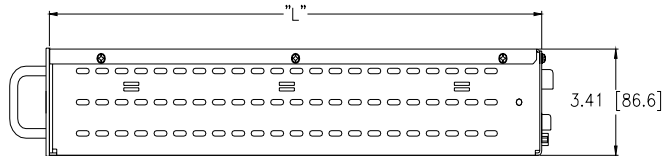

Figure 2.1 XLG & XLF DIMENSIONS

Chapter 3

Operating Instructions

3.1 Operation

WARNING

THIS EQUIPMENT GENERATES DANGEROUS VOLTAGES THAT MAY BE FATAL. PROPER GROUNDING OF ALL HIGH VOLTAGE EQUIPMENT IS ESSENTIAL.

WARNING:

Before connecting the power supply to the AC line, follow this step-by-step procedure. Do not connect the power supply to the AC line until Step H is reached. Failure to follow these procedures may void the warranty.

A) Insure that the Circuit Breaker is in the OFF position (0).

B) Check the input voltage rating on the nameplate of the supply and make certain that this is the rating of the available power source. Spellman XLG/XLF units operate on 115VAC (or 220V if 220 V option is ordered), single phase unless ordered with a different input voltage.

C) **PROPER GROUNDING TECHNIQUE:** The chassis of high voltage power supplies must be grounded, preferably to a water system ground using copper pipe or other earth ground using the connection terminal at the rear of the unit.. See Figure 3.1, 3.2 for a typical operating setup.

The return line from the load should be connected to the terminal on the rear of the power supply. Using a separate external ground at the load is not recommended.

The units are provided with a three conductor line cord.

D) Attach the output cable to the load.

E) Plug the high-voltage output cable into the rear of the supply and hand tighten the knurled collar.

F) **Options Note:** See section 5 for hook up and operating instructions for the options on your unit. Custom models may also require set up changes.

G) For initial turn-on, rotate the KILOVOLT control fully counter-clockwise to the zero voltage position.

H) The input power cable may now be connected to the AC power line.

I) Switch the front panel circuit breaker to the ON position (1). (If the supply is to be turned off for an extended period of time the line cord should be disconnected). The unit is now in the HIGH VOLTAGE OFF mode. The HIGH VOLTAGE OFF light should be lit.

J) Depress and hold the HIGH VOLTAGE OFF switch. The front panel meters will now read the preset value of the KILOVOLT control dial and the MILLAMPERES control dial. To preset the desired level of the current and voltage during operation, hold the HIGH VOLTAGE OFF switch and rotate the appropriate control dial while noting its corresponding meter reading. Release the HIGH VOLTAGE OFF switch.

NOTE: No actual output is being produced at this stage.

K) Depress the HIGH VOLTAGE ON switch. The light inside the switch should light up and the output will slow start to the preset level output voltage and/or output current.

Note: The XLG/XLF series is equipped with a slow start circuit that ramps the output up to its maximum setting in approximately 6 seconds after the HIGH VOLTAGE ON switch is depressed.

L) To terminate the generation of output power, depress the HIGH VOLTAGE OFF switch. In the HIGH VOLTAGE OFF mode the power supply's fault and interface circuits are still active.

M) To turn off the power supply, turn the circuit breaker to the off position (0).

NOTE: If a power supply fault, or system monitoring fault occurs, the power supply will revert to the POWER DOWN mode. In this mode the output power will be turned off. The HV OFF lamp will be off. To reset, depress the HV OFF Switch.

WARNING

**AFTER TURNOFF, DO NOT HANDLE THE LOAD UNTIL THE CAPACITANCE HAS BEEN DISCHARGED!
LOAD CAPACITANCE MAY BE DISCHARGED BY SHORTING TO GROUND.**

WARNING

THE VOLTMETER ON THE POWER SUPPLY FRONT PANEL DOES NOT READ THE OUTPUT VOLTAGE WHEN THE POWER IS TURNED OFF, EVEN IF A CHARGE STILL EXISTS ON THE LOAD.

CAUTION

ALWAYS OPERATE THE UNIT WITH THE COVER ON.

A fan maintains safe operating temperature in the XLF power supplies by drawing air over the circuit components. The cover must be on in order to direct the air flow over the areas that need cooling. In operation, the unit must be placed so that the air intake and the fan exhaust are clear of any obstructions that might impede the flow of air. The XLG units do not use forced air cooling. Simply maintain ambient temperature specifications.

3.2 Standard Features

A note on remote interface circuitry and remote signal grounding. Whenever possible, electrical isolation should be provided when interfacing with any high voltage power supply. For power control signals such as EXTERNAL INTERLOCK, HIGH VOLTAGE OFF and HIGH VOLTAGE ON isolated relay contacts should be used. For status signals and control signals such as HIGH VOLTAGE ON, HIGH VOLTAGE OFF, EXTERNAL INHIBIT, etc. Opto-isolation should be used. If possible, analog programming and monitoring signals should be isolated via analog isolation amplifiers. Spellman application engineers are available to assist in interface circuitry design. All interface cables should be properly shielded. All power supply signals should be referenced to the power supplies signal ground on the rear terminal block JB1-1.

REMOTE PROGRAMMING: Allows remote adjustment of the output voltage and current via an external voltage source. (Output power is also remotely controllable with the CPC and APT options). In local

control (front panel control), jumpers are installed on the connector JB1 in the rear of the chassis between JB1-10 and JB1-11 for voltage control and between JB1-8 and JB1-9 for current control.

For remote programming, the jumpers are removed and a positive voltage source, from 0 to 10 volts, is applied to the appropriate terminals. Programming signals should be referenced to JB1-1 signal ground. By adjusting the voltage source from 0 volts (zero output) to 10 volts (full rated output) the desired output can be selected. See Figure 3.3A for wiring diagram and specifications.

An alternate method of controlling the output remotely is by using external resistance such as a potentiometer or a resistor network. For remote control the jumpers are removed and the desired resistor configuration is installed. See Figure 3.3B for wiring diagram.

REMOTE MONITOR: Test points are made available on the rear of the chassis for monitoring the voltage and current output. (Output power monitor is included with the CPC and APT option). The test points are always positive regardless of the output polarity, where zero 0 to 10 volts equals 0-100% of output $\pm 0.5\%$. Test points have an output impedance of 5k ohms. See Figure 3.4 for test point designation.

REMOTE CONTROL: Remote control of the POWER ON, HIGH VOLTAGE ON and HIGH VOLTAGE OFF can be accomplished via the rear panel interface. The POWER ON control is an on-off toggle contact. HIGH VOLTAGE OFF and HIGH VOLTAGE ON are controlled by momentary normally closed normally open contacts, respectively. See Figure 3.5 for recommended interface.

EXTERNAL INHIBIT: Allows the user to inhibit the power supply output without switching HIGH VOLTAGE OFF control. This circuit can be used to generate fast slewing output waveforms or control high voltage generation as in Laser and Capacitor discharge applications. The maximum inhibit rate should not exceed 5Hz. Consult factory for higher repetition rates or high pulse load applications. See Figure 3.6 for the recommended interface circuit.

WARNING

It is extremely dangerous to use this Inhibit circuit to inhibit high voltage generation for the purpose of servicing or approaching any area of load considered unsafe during normal use.

EXTERNAL INTERLOCK: Interlock connections are provided on the terminal on the rear of the chassis for connection to a safety switch. The unit will not operate unless the interlock circuit is closed. If the interlock is not being used, the jumper installed on the terminals before shipping *must* be in place. If the jumper is missing, or there is an open between the interlock terminals the unit's high voltage inverter will be disabled. During high voltage operation, opening the interlock circuit will cause the unit to revert to the HIGH VOLTAGE OFF mode. Subsequent closing of the interlock circuit will NOT return the unit to HIGH VOLTAGE ON mode, this must be accomplished by depressing the HIGH VOLTAGE ON switch. See Figure 3.7 for the recommended interface circuit.

ARC DETECT / ARC QUENCH ARC COUNT: The ARC DETECT circuit senses dynamic arcing or discharge conditions present at the output load. If an arc occurs, the output is inhibited for one second. After the one-second period, the output is ramped up to the previous set level. This ramp is based on the standard six-second slow start feature. The ARC DETECT ramp circuit may be disabled by removing CR32 on the Control/Power PWB. Caution should be observed if this

feature is disabled. Discharge rates of greater than 1 Hz may cause excessive power dissipation in the power supply's output limiting resistors.

The ARC COUNT feature will allow the user to program the ARC fault parameters. The ARC indicator on the front panel will illuminate for approximately one second after each arc has occurred. The power supply can be programmed to trip to the POWER DOWN mode if an arc occurs. The standard feature is programmed to trip the power supply if 8 arcs occur within a twenty second period. Details for programming the ARC COUNT feature are provided on schematics, at the end of this manual.

REMOTE HIGH VOLTAGE ON & REMOTE HIGH VOLTAGE OFF: Signals are provided for remote monitoring of the HIGH VOLTAGE ON/OFF status. See Figure 3.8 for recommended interface.

REMOTE MODE INDICATORS: Signals are provided for remote indication of the control mode status, voltage control, current control and power control. See Figure 3.9 for the recommended interface.

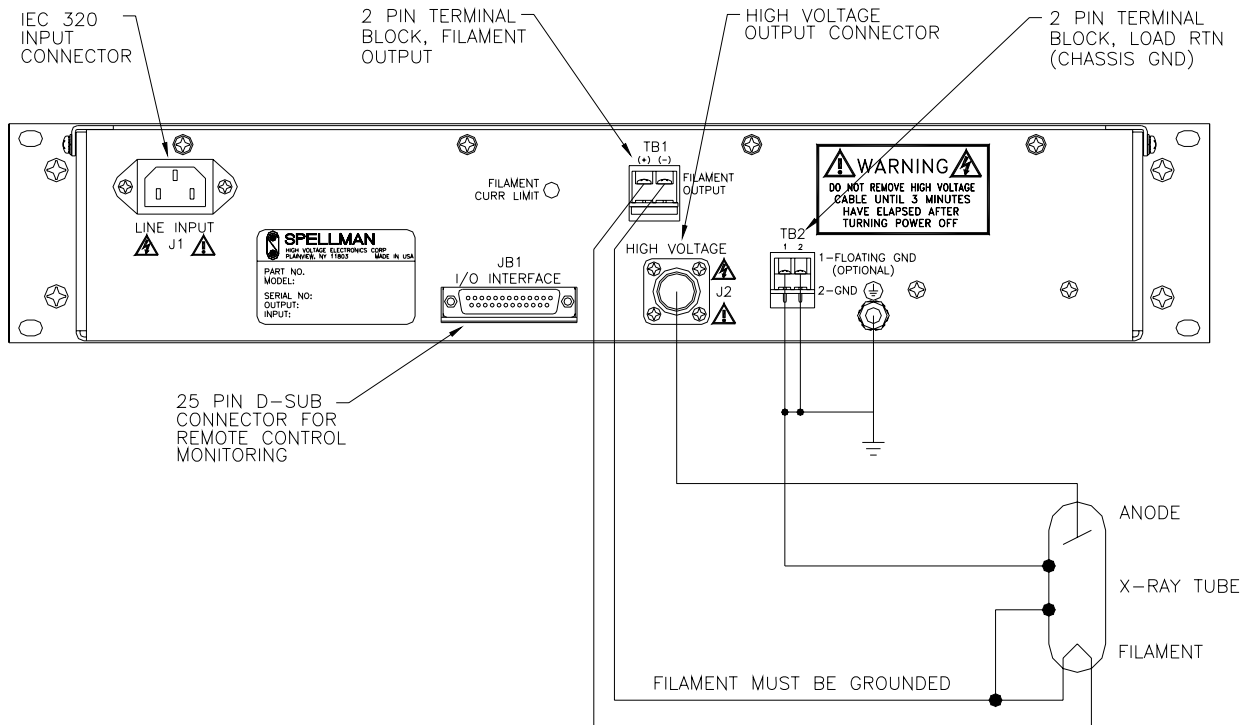

Figure 3.1 Typical Operating Setup XLG

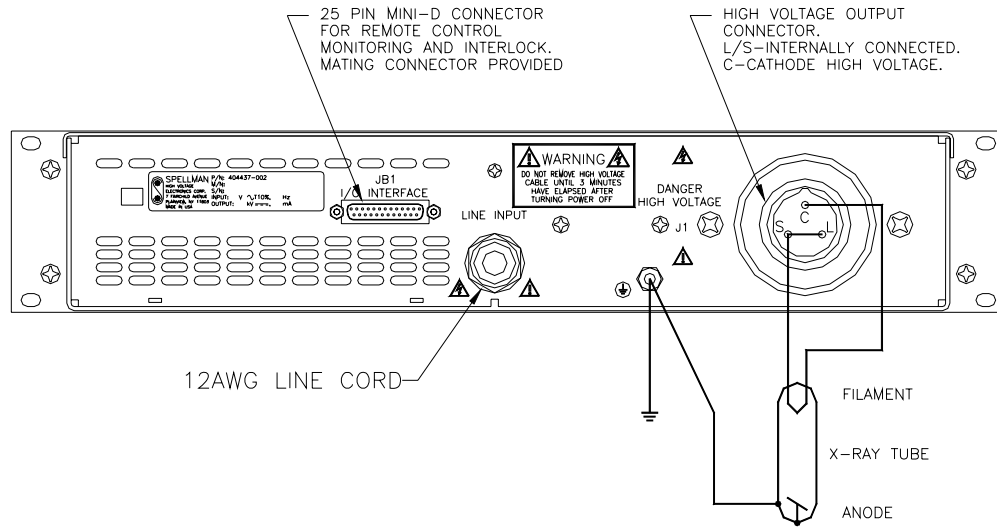

Figure 3.2 Typical Operating Setup XLF

JB1	SIGNAL	SIGNAL PARAMETERS
1	Power Supply Common	Signal Ground
2	External Inhibit	Ground = Inhibit, Open = HV ON
3	External Interlock	+15V at Open, <15mA at Closed
4	External Interlock Return	Return for Interlock
5	Current Monitor	0 to 10V = 0 to 100% rated output
6	KV Test Point	0 to 10V = 0 to 100% rated output
7	+ 10V Reference	+10.24V, 1mA max.
8	Remote Current Program In	0 to 10V = 0 to 100% rated output
9	Local Current Program Out	Front Panel Program Voltage
10	Remote Voltage Program In	0 to 10V = 0 to 100% rated output
11	Local Voltage Program Out	Front Panel Program Voltage
12	Power Monitor	0 to 10V = 0 to 100% rated output
13	Remote Power Program In	(Optional)
14	Local HV OFF Out	+15V at Open, <25mA at Closed
15	HV OFF	Connect to HV OFF for FP operation.
16	Remote HV ON	+15V, 10mA max = HV ON
17	Remote HV OFF Indicator	0 = HV ON, +15V, 10mA max = HV OFF
18	Remote HV ON Indicator	0 = HV OFF, +15V, 10mA max = HV ON
19	Remote Voltage Mode	Open Collector 50V max, 10mA max, On = Active
20	Remote Current Mode	
21	Remote Power Mode	
22	Remote PS Fault	0 = Fault, +15V, 1mA max = No Fault
23	+ 15V Output	+15V, 100mA max
24	Power Supply Common	Signal Ground

Table 3.1 Rear Panel Interface

Voltage Source 0-10V = 0-100% of Rated Output

It is recommended that analog signals be isolated via isolation amplifiers.

All cables should be shielded with the shields being returned to the chassis ground of the High Voltage Power Supply.

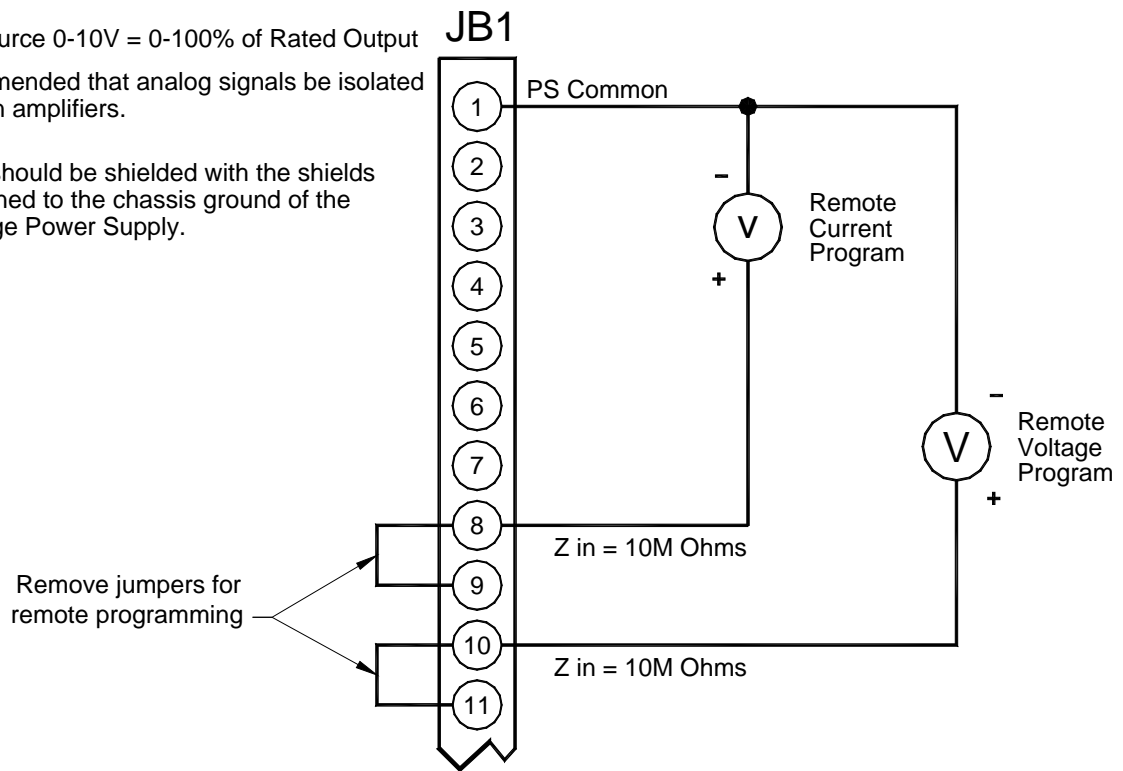

Figure 3.3A Wiring Diagram for Remote Programming Via Voltage Source

Fully Counterclockwise = Zero Output
Fully Clockwise = 100% of Rated Output

All cables should be shielded with the shields being returned to the chassis ground of the High Voltage Power Supply.

If connections to external potentiometers are excessively long (>10 ft), motorized potentiometers are recommended.

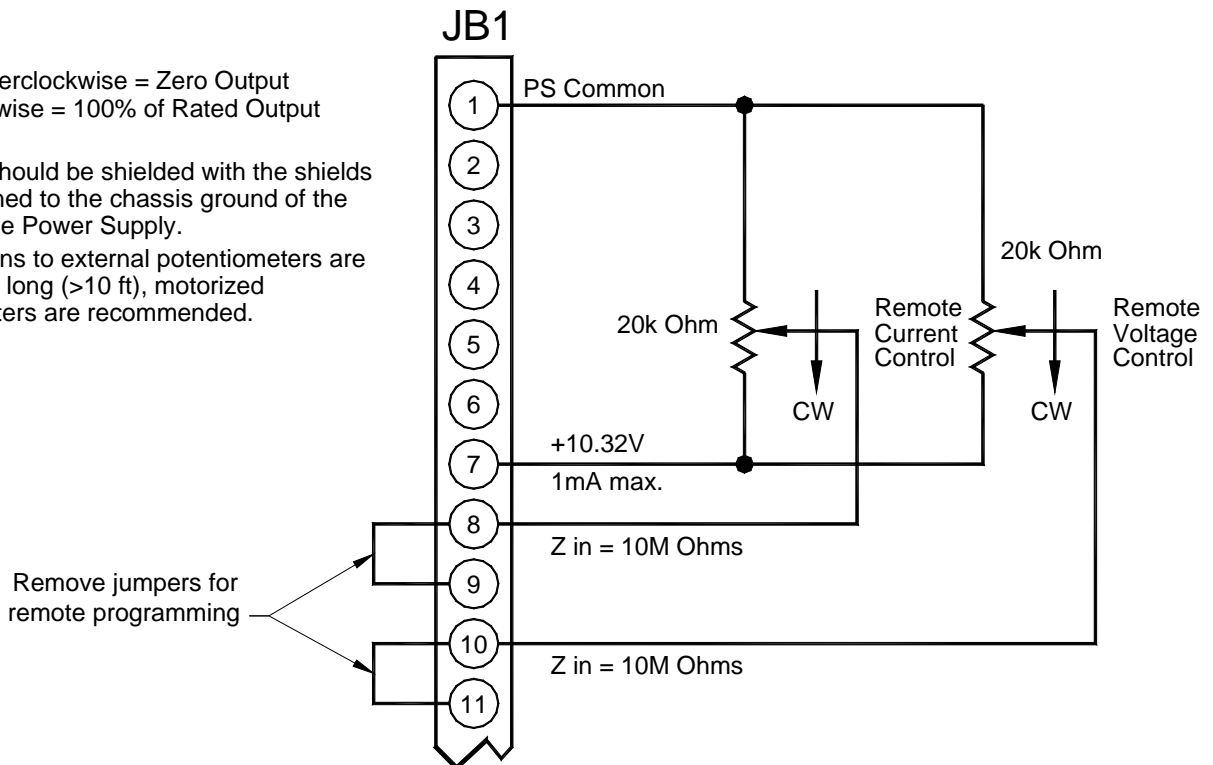

Figure 3.3B Wiring Diagram for Remote Programming Via External Resistance

It is recommended that analog signals be isolated via isolation amplifiers.

All cables should be shielded with the shields being returned to the chassis ground of the High Voltage Power Supply.

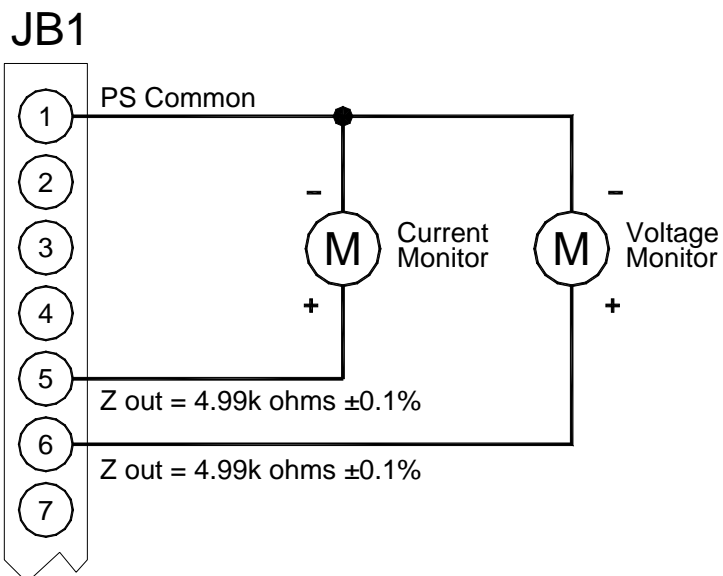

Figure 3.4 Remote Monitor Test Point Designations

It is recommended to use relay contacts for S1 and S2. Relays should be located as close as possible to the high voltage power supply. Coils should be driven from

isolated sources. Signals are at ϕ 15Vdc, 25mA max, and are only to be used for contact closure.

S1 must be closed to enable HIGH VOLTAGE ON.

Remove jumper for remote high voltage control

All cables should be shielded with the shields being returned to the chassis ground of the High Voltage Power Supply.

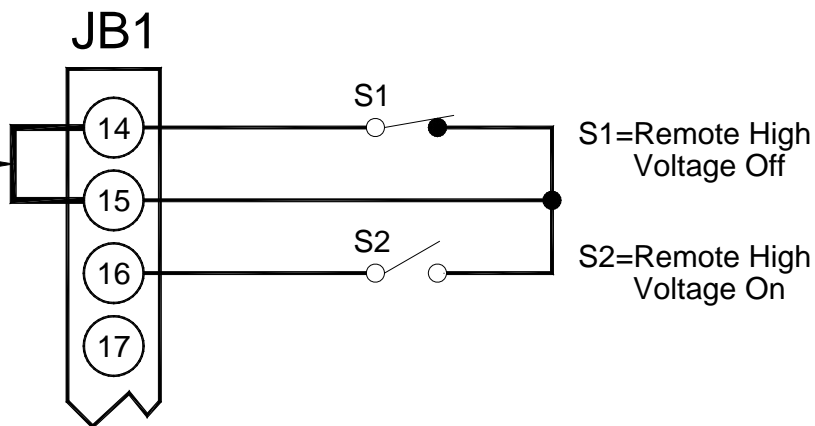

Figure 3.5 Remote Control of High Voltage ON and High Voltage OFF Interface

Transistor should be located as close as possible to the power supply.

All cables should be shielded with the shields being returned to chassis ground of the High Voltage Power Supply.

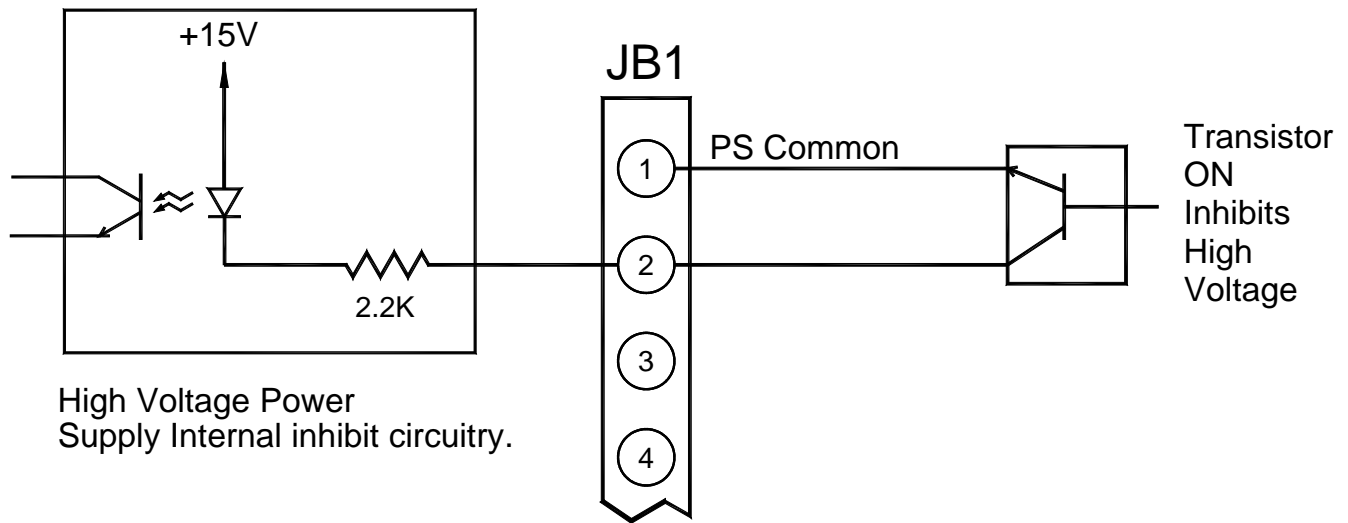
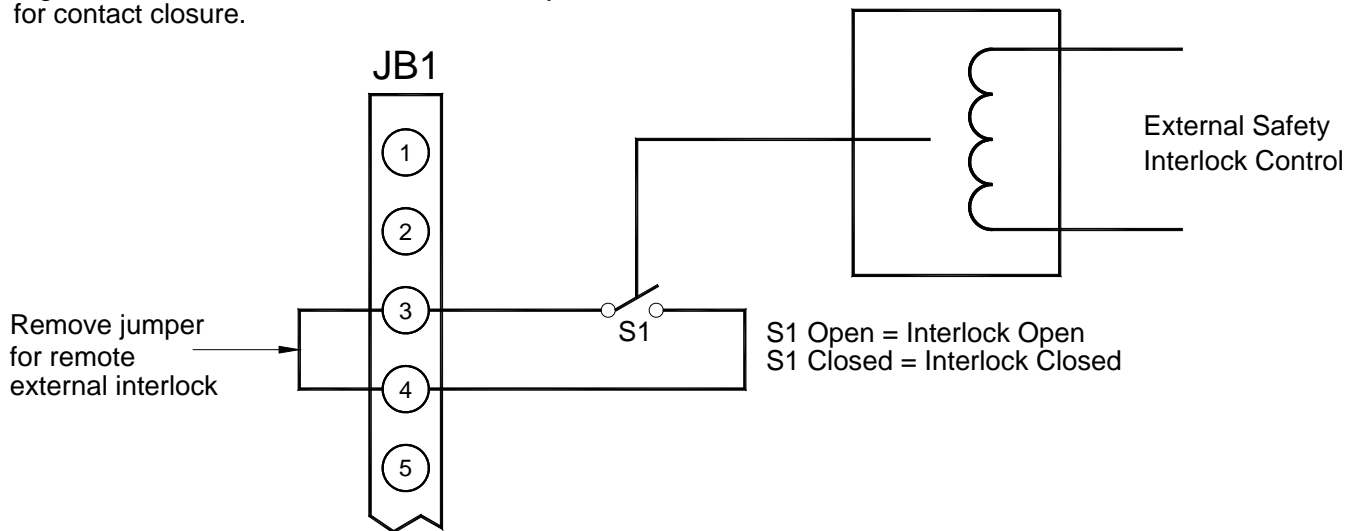

Figure 3.6 External Inhibit Interface Circuit

It is recommended to use relay contacts for S1. The relay should be located as close as possible to the power supply. Signals are ~15Vdc, 25mA max and are only to be used for contact closure.



All cables should be shielded with the shields being returned to chassis ground of the High Voltage Power Supply.

Figure 3.7 External Interlock Interface

12Vdc lamps or relay coils may replace opto-couplers.
 Opto-couplers, lamps or relays should be located as close
 as possible to the high voltage power supply.
 All cables should be shielded with the shields being returned
 to chassis ground of the High Voltage Power Supply.

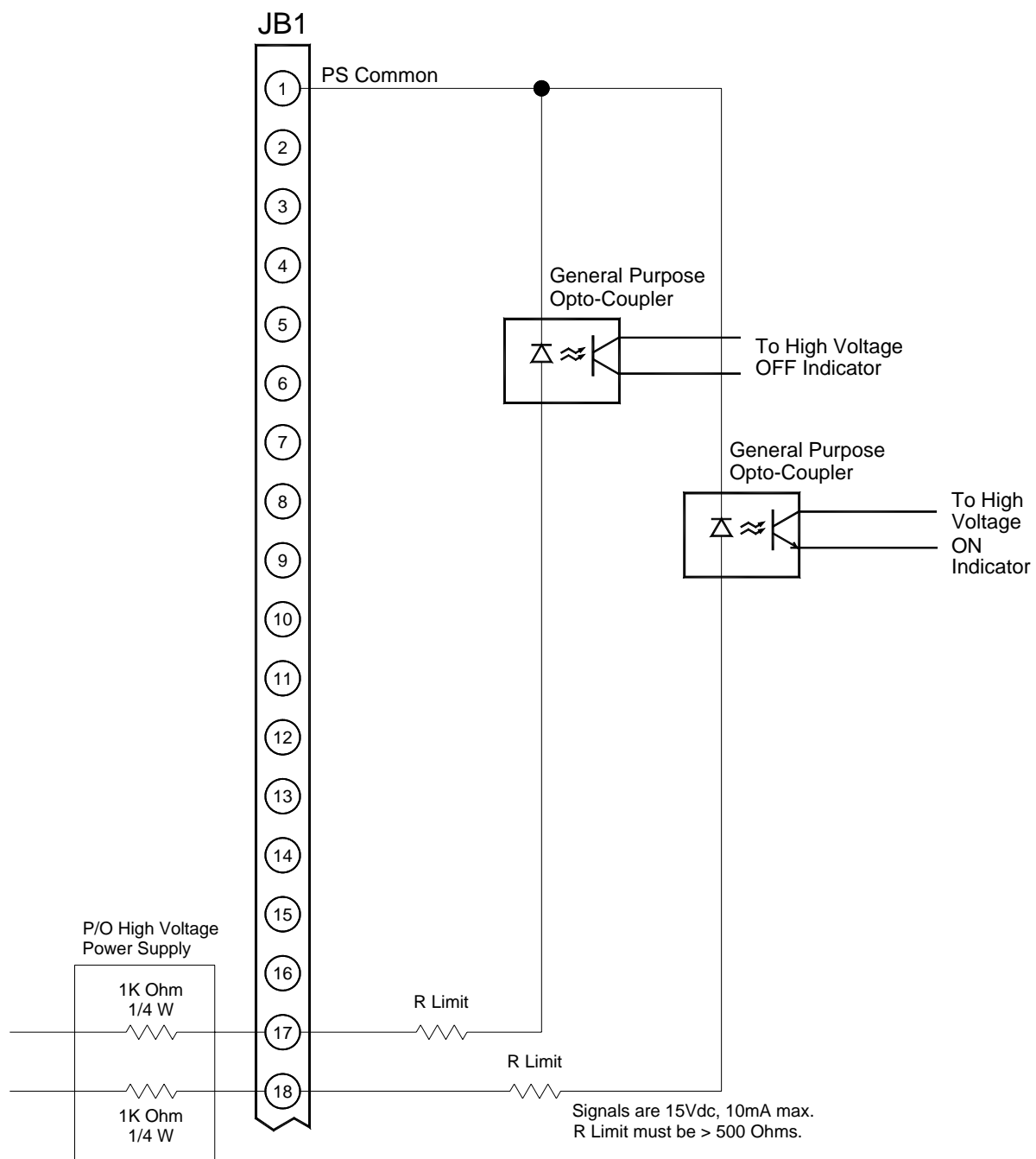

Figure 3.8 Remote High Voltage ON and Remote High Voltage OFF Indicator Circuit

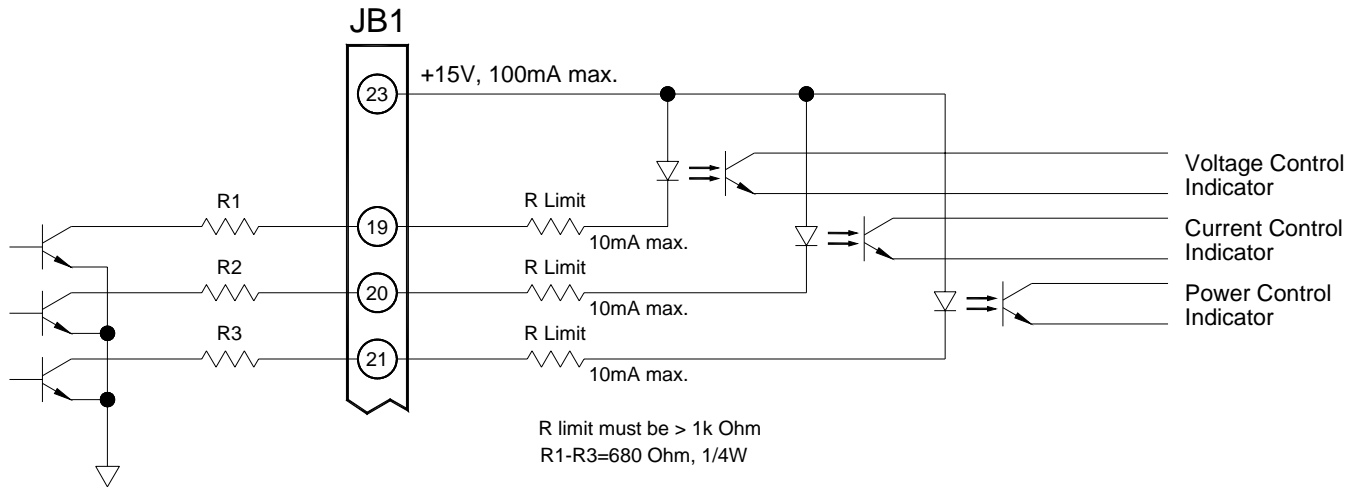

Figure 3.9 Remote Mode Indicators Interface

Chapter 4

PRINCIPLES OF OPERATION

The XLG/XLF series of high voltage power supplies utilizes sophisticated power conversion technology.

A variety of analog, digital and power conversion techniques are used throughout. The intention of the Principles of Operation is to introduce the basic function blocks that comprise the XLG/XLF power supply. For details on a specific circuit, consult Spellman's Engineering Department.

See Table 4.1 for a list of the main assemblies found in a typical XLG/XLF power supply.

* Due to the many variations within the XLG/XLF series, drawing numbers may differ from unit to unit.

The XLG/XLF power supply is basically an AC to DC converter. Within the power supply, conversions of AC to DC, then high frequency AC, then to high voltage DC take place. By reviewing further the sub-assemblies, a basic understanding of the process can be gained.

4.1 Chassis

The XLG/XLF is a compact, high efficiency, high voltage power supply. The power supply can supply up to 600 watts of DC power. (Output power capability may be higher or lower depending upon model ordered). Output voltages of up to 130kV can be generated.

WARNING

The energy levels used and generated by the power supply can be lethal! Do not attempt to operate the power supply unless the user has a sufficient knowledge of the dangers and hazards of working with high voltage. Do not attempt to approach or touch any internal or external circuits or components that are connected or have been connected to the power supply. Be certain to discharge any stored energy that may be present before and after the power supply is used. Consult IEEE recommended practices for safety in high voltage testing #510-1983.

4.2 Line Rectification and Filtering

Basic single phase rectification provides the DC voltage for the high frequency inverter. The line input voltage can vary from 90 up to 242 volts within the XLG/XLF series.

In general, the following variations can be ordered:

100Vac $\pm 10\%$, 50/60Hz, single phase.

115Vac $\pm 10\%$, 50/60Hz, single phase.

200Vac $\pm 10\%$, 50/60Hz, single phase.

220Vac $\pm 10\%$, 50/60Hz, single phase.

Other input voltages can be accommodated. If the user is unsure which input voltage option is supplied, check the serial tag on the rear of the power supply or consult Spellman's Sales Department

Circuit protection is provided by CB1 (SYSTEM BLOCK DIAGRAM CHASSIS XLG/XLF SCHEMATIC). CB1 is a fast acting magnetic trip type circuit breaker. The line input is connected directly to the line side of CB1. The load side of CB1 is connected to the CONTROL/POWER PWB. The load side of CB1 is also connected to T1. T1 is a step-down type line transformer. T1 provides voltage for housekeeping and control circuit power.

WARNING

LINE VOLTAGE IS PRESENT WHENEVER THE POWER SUPPLY IS CONNECTED TO EXTERNAL LINE VOLTAGES. BE SURE TO DISCONNECT THE LINE CORD BEFORE OPENING THE UNIT. ALLOW 5 MINUTES FOR INTERNAL CAPACITANCE TO DISCHARGE BEFORE REMOVING ANY COVER.

When CB1 is ON, voltage is applied to CR10. CR10 is an isolated diode rectifier bridge that contains the rectifier diodes used for line voltage rectification. The output of CR10 is connected to a capacitor filter (C7 through C10). Capacitors are initially charged through NTC type or resistive inrush limiters.

Approximately 1 second after CB1 is turned on, a relay is energized to short the NTC or resistor limiters. This relay is K1. This DC voltage is supplied to the high frequency inverter.

The DC rails are connected to the high frequency rail capacitors. These capacitors are high frequency, low loss type. Capacitors C11, C12, C54, and C55 provide the energy storage for the high frequency inverter.

	XLG		XLF	
ASSEMBLY TITLE	ASSEMBLY NO.	SCHEMATIC NO.	ASSEMBLY NO.	SCHEMATIC NO.
Chassis	404486-001	440530-009	404437-002	440643-001
Power/Cont Bd (30 – 60kV) (80 – 130kV)	450038-005 450038-006	440894-001	450047-004	440884-004
Multiplier Assy (30 – 60kV) (80 – 130kV)	403932-061 403970-131	440533-001 440533-002	404438-TAB	440648-001
Filament Board	404241-003	440606-001	404241-002	440606-001
Front Panel Bd (30 – 60kV) (80 – 130kV)	403895-001 403895-002	440525-001	403895-001	440528-001

Table 4.1 List of Main Assemblies

4.3 Inverter

The inverter is a series resonant, series/parallel loaded topology. A proprietary control scheme is used for regulating the power generated from the inverter. Q2, Q3, Q4, and Q5 are high speed Mosfets. These devices provide high frequency switching to control the resonant current flow. The typical resonant operating period is approximately 10uSeconds. The gate control for the switching devices is provided by T2 on the CONTROL/POWER PWB. The CONTROL/POWER PWB also provides circuitry for sensing shoot thru and over current conditions in the inverter. U10 and its associated circuitry automatically shutdown the inverter. U18 provides for the gates high current pulse requirements. T2 provides line voltage isolation

4.4 High Voltage Transformer

The output of the High Frequency Resonant Inverter is connected to the primary of the High Voltage Transformer. The High Voltage Transformer is a step-up type. Typically secondary voltages are in the range of 1kV to 4.5kV depending upon output voltage ratings.

4.5 High Voltage Assembly

The High Voltage Assembly will vary depending upon the model ordered. The circuitry typically consists of a full wave, full bridge. The higher voltage ranges utilize various parallel, series arrangements of a full wave voltage doubler.

Output filtering is typically provided by an R-C type filter. Voltage feedback for regulation and monitoring is provided by a high bandwidth resistive/capacitive divider.

Current feedback for regulation and monitoring is provided by a sense resistor connected at the low voltage end of the High Voltage Rectifier/Multiplier Circuit.

4.6 Control/Power PWB

The majority of control circuits for power supply controls are located on the CONTROL/POWER PWB.

+15VDC, -15VDC, and +10VDC is generated on the CONTROL/POWER PWB. High Voltage On/Off control is accomplished by K3, and its associated circuitry. Interlock control is provided by K4.

Voltage feedback from the high voltage divider is sent to U6. Gain adjust is provided on the HV PWB. The KV feedback signal is sent to the front panel DVM and to the REAR PANEL TERMINAL BLOCK for remote monitoring. K2 provides switching between feedback and program signal for the front panel DVM's. This allows the user to preset the desired output before energizing high voltage.

Program voltages are typically ramped up to set level by the slow start circuits of U7.

Arc sense circuits U14 and U23 provide sensing, quench and indication of arc conditions. Consult operation manual for a detailed description of the arc sense control.

Current feedback from the high voltage rectifier is sent to sense resistors located on the High Voltage Assembly. Calibrated feedback is then sent to U4.

An overvoltage protection circuit provides protection in the unlikely event of a main control loop failure. U9 provides gain adjustments for the overvoltage protection (OVP) control.

U12 and U13 circuits provide visual indication of the control mode, which is in operation. These signals are sent to the FRONT PANEL ASSEMBLY for front panel status indication.

The resonant control circuitry consists of a voltage to pulse width converter. U17 generates all frequency and pulse width control signals. U16 provides specific control functions for the resonant control.

Power supply inhibit circuits are provided by U22 and K3. System Fault Control and Indication is provided by U19m U20, and U21 and associated circuitry. Diagnostic signals are latched and then sent to the FRONT PANEL ASSEMBLY for status indication.

4.7 Front Panel Assembly

Front Panel control meters, and status indications are connected to the FRONT PANEL PWB. The FRONT

PANEL PWB interfaces directly to the CONTROL/POWER PWB.

4.8 Filament Supply PWB

The power for the X-ray tube is provided by the filament inverter. The filament inverter is a high frequency, series resonant inverter. The inverter provides regulated current to the primary of the filament transformer. The filament isolation transformer is then connected to the output connector.

4.9 Options

Due to the many variations of models and options provided in the XLG/XLF series, details of actual circuits used may differ slightly from above descriptions. Consult Spellman's Engineering Department for questions regarding the principles of operations for the XLG/XLF series.

Chapter 5

OPTIONS

The options available for this power supply are described in this section. Interface diagrams are shown where required. Options are specified by including the option code in the model number as described in Section 1.5.

5.1 Adjustable Overload Trip

AOL

The overload trip protection feature rapidly shuts down the high voltage output when the load current exceeds the limit set by the current control dial on the front panel. A fast acting circuit inhibits the generation of high voltage and reverts the unit to POWER DOWN mode, illuminating the OVER CURRENT indicator. When adjustable overload trip is provided, it replaces the standard current regulation feature.

5.2 220V AC Single Phase Input

220

XLG/XLF power supplies with the 220 V AC input option will operate from an input voltage of 220VAC rms $\pm 10\%$, 50-60Hz, single phase.

5.3 No Slow Start

NSS

The no slow start option causes the output voltage of the power supply to rise (within 50 msec) to the rated voltage upon depressing the HIGH VOLTAGE ON Switch.

5.4 Non-Standard Slow Start

SS(x)

The non-standard slow start option allows the gradual rise time of the output voltage to be different from the standard of six seconds. To order the option, place the time desired in seconds after the suffix letter; i.e. SS(10) denotes a 10 second rise time.

5.5 Extra Length Output Cable

LL(ft)

Standard output cable is 10' of shielded high voltage cable. Other lengths may be specified in multiples of 10 feet.

5.6 Adjustable Power Trip

APT

The power control options allow monitoring and control of the power supply output power. The APT option allows the user to remotely adjust the power limit for the power supply. If the power limit is exceeded, the unit will shut down with an OVERPOWER fault. See Figure 5.2 or remote interface.

5.7 Arc Trip Option

AT

When this option is ordered, the ARC Count circuit is set so the unit trips to Standby after 1 count.

One of the applications for this option is for sensing material breakdown under an applied high voltage.

5.8 Instant On

IO

When the Instant On option is ordered, the High Voltage is enabled as soon as line voltage is applied when the circuit breaker is in the ON position.

To enable Instant ON, keep the jumper between JB1-14 and JB1-15 attached. Connect an additional jumper from JB1-15 to JB1-16 as shown in Figure 5.1

CAUTION

The Power Supply will generate programmed High Voltage whenever the circuit breaker is in the ON position, and line voltage is applied.

5.9 Custom Designed Models X(#)

Units built to customer specifications are assigned an X number by the factory. If this unit is an X model, specification control sheet is added at the end of this instruction manual.

Spellman welcomes the opportunity to tailor units to fit your requirements or to develop new products for your applications. Contact Spellman Sales Department with your needs.

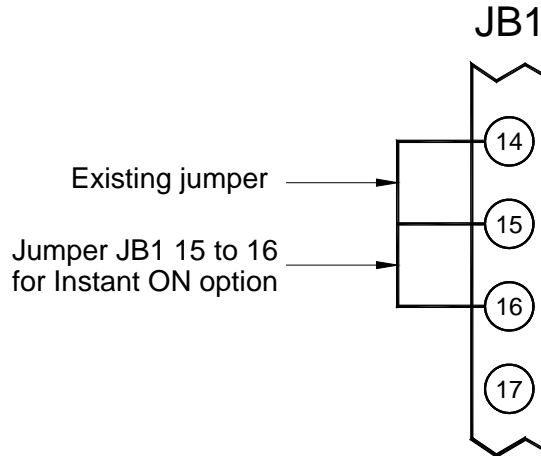

Figure 5.1 Instant ON

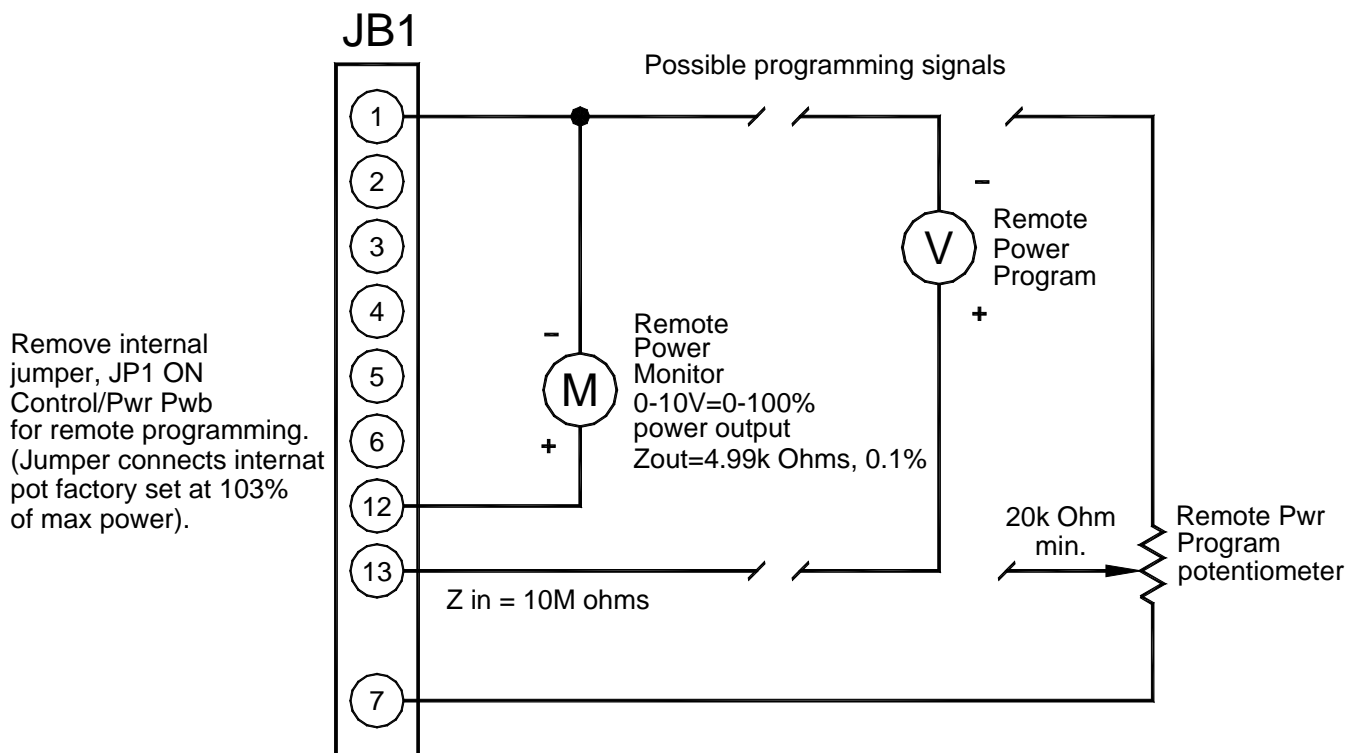

Figure 5.2 Adjustable Power Remote Interface

Chapter 6

MAINTENANCE

This section describes periodic servicing and performance testing procedures.

WARNING

THIS POWER SUPPLY GENERATES VOLTAGES THAT ARE DANGEROUS AND MAY BE FATAL. OBSERVE EXTREME CAUTION WHEN WORKING WITH HIGH VOLTAGE.

6.1 Periodic Servicing

Approximately once a year (more often in high dust environments), disconnect the power to the unit and remove the top cover. Use compressed air to blow dust out of the inside of the unit. Avoid touching or handling the high voltage assembly. Be sure that the fan is not obstructed and spins freely. The fan has sealed bearings and does not need lubrication. Be sure to replace the top cover before operating for proper cooling.

6.2 Performance Test

WARNING

**HIGH VOLTAGE IS DANGEROUS.
ONLY QUALIFIED PERSONNEL SHOULD
PERFORM THESE TESTS.**

High voltage test procedures are described in Bulletin STP-783, Standard Test Procedures for High Voltage Power Supplies. Copies can be obtained from the Spellman Customer Service Department. Test equipment, including an oscilloscope, a high impedance voltmeter, and a high voltage divider such as the Spellman HVD-100 or HVD-200, is needed for performance tests. All test components must be rated for operating voltage.

6.3 High Voltage Dividers

High voltage dividers for precise measurements of output voltage with an accuracy up to 0.1% are available from Spellman. The HVD-100 is used for voltages up to 100KV. The HVD-200 measures up to 200KV. The Spellman divider is designed for use with differential voltmeters or high impedance digital voltmeters. The high input impedance is ideal for measuring high voltage low current sources, which would be overloaded by traditional lower impedance dividers.

Chapter 7

REPLACEMENT PARTS

7.1 Replacement Parts

Contact the Spellman Customer Service Department for parts lists for specific models.

Spellman provides parts and subassemblies for its high voltage power supplies but recommends that only qualified personnel perform the repair. High voltage is dangerous; even minor mistakes in repairs can have serious consequences.

When requesting parts please give the model number and serial number of the power supply

7.2 Correspondence And Ordering Spare Parts

Each Spellman power supply has an identification label on the rear of the chassis that bears its model and serial number.

When requesting engineering or applications information, please state the model and serial number of the power supply. If specific components or circuit sections are involved in the inquiry, it is helpful to indicate the component symbol number(s) shown on the applicable schematic diagram.

When ordering spare parts, please specify the part's description, the part's reference designation or part number, and the model and serial number of the unit.

Chapter 8

FACTORY SERVICE

8.1 Warranty Repairs

During the Warranty period, Spellman will repair all units free of charge. The Warranty is void if the unit is worked on by other than Spellman personnel. See the Warranty in the rear of this manual for more information. Follow the return procedures described in Section 8.2. The customer shall pay for shipping to and from Spellman.

8.2 Factory Service Procedures

Spellman has a well-equipped factory repair department. If a unit is returned to the factory for calibration or repair, a detailed description of the specific problem should be attached.

For all units returned for repair, please obtain an authorization to ship from the Customer Service Department, either by phone or mail prior to shipping. When you call, please state the model and serial numbers, which are on the plate on the rear of the power supply, and the purchase order number for the repair. A Return Material Authorization Code Number (RMA Number) is needed for all returns. This RMA Number should be marked clearly on the outside of the shipping container. Packages received without an RMA Number will be returned to the customer. The Customer shall pay for shipping to and from Spellman.

A preliminary estimate for repairs will be given by phone by Customer Service. A purchase order for this amount is requested upon issuance of the RMA Number. A more detailed estimate will be made when the power supply is received at the Spellman Repair Center. In the event that repair work is extensive, Spellman will call to seek additional authorization from your company before completing the repairs.

8.3 Ordering Options And Modifications

Many of the options listed in Chapter 5 can be retrofitted into Spellman power supplies by our factory. For prices and arrangements, contact our Sales Department.

8.4 Shipping Instructions

All power supplies returned to Spellman must be sent shipping prepaid. Pack the units carefully and securely in a suitable container, preferably in the original container, if available. The power supply should be surrounded by at least four inches of shock absorbing material. Please return all associated materials, i.e. high voltage output cables, interconnection cables, etc., so that we can examine and test the entire system.

All correspondence and phone calls should be directed to:

Spellman High Voltage Electronics Corp.

475 Wireless Boulevard

Hauppauge, New York 11788

TEL: (631) 630-3000 FAX: (631) 435-1620

E-Mail: sales@Spellmanhv.com

<http://www.spellmanhv.com>

SPELLMAN HIGH VOLTAGE ELECTRONICS

WARRANTY

Spellman High Voltage Electronics ("**Spellman**") warrants that all power supplies it manufactures will be free from defects in materials and factory workmanship, and agrees to repair or replace, without charge, any power supply that under normal use, operating conditions and maintenance reveals during the warranty period a defect in materials or factory workmanship. The warranty period is twelve (12) months from the date of shipment of the power supply. With respect to standard SL power supplies (not customized) the warranty period is thirty-six (36) months from the date of shipment of the power supply.

This warranty does not apply to any power supply that has been:

- Disassembled, altered, tampered, repaired or worked on by persons unauthorized by **Spellman**;
- subjected to misuse, negligent handling, or accident not caused by the power supply;
- installed, connected, adjusted, or used other than in accordance with the original intended application and/or instructions furnished by **Spellman**.

THE FOREGOING WARRANTY IS IN LIEU OF ALL OTHER WARRANTIES, EXPRESS OR IMPLIED, INCLUDING THOSE OF MERCHANTABILITY OR FITNESS FOR A PARTICULAR PURPOSE.

The buyer's sole remedy for a claimed breach of this warranty, and **Spellman's** sole liability is limited, at **Spellman's** discretion, to a refund of the purchase price or the repair or replacement of the power supply at **Spellman's** cost. The buyer will be responsible for shipping charges to and from **Spellman's** plant. The buyer will not be entitled to make claim for, or recover, any anticipatory profits, or incidental, special or consequential damages resulting from, or in any way relating to, an alleged breach of this warranty.

No modification, amendment, supplement, addition, or other variation of this warranty will be binding unless it is set forth in a written instrument signed by an authorized officer of **Spellman**.

Factory Service Procedures

For an authorization to ship contact **Spellman's** Customer Service Department. Please state the model and serial numbers, which are on the plate on the rear panel of the power supply and the reason for return. A Return Material Authorization Code Number (RMA number) is needed from **Spellman** for all returns. The RMA number should be marked clearly on the outside of the shipping container. Packages received without an RMA Number may delay return of the product. The buyer shall pay shipping costs to and from **Spellman**. Customer Service will provide the Standard Cost for out-of-warranty repairs. A purchase order for this amount is requested upon issuance of the RMA Number (in-warranty returns must also be accompanied by a "zero-value" purchase order). A more detailed estimate may be made when the power supply is received at **Spellman**. In the event that the cost of the actual repair exceeds the estimate, **Spellman** will contact the customer to authorize the repair.

Factory Service Warranty

Spellman will warrant for three (3) months or balance of product warranty, whichever is longer, the repaired assembly/part/unit. If the same problem shall occur within this warranty period **Spellman** shall undertake all the work to rectify the problem with no charge and/or cost to the buyer. Should the cause of the problem be proven to have a source different from the one that has caused the previous problem and/or negligence of the buyer, **Spellman** will be entitled to be paid for the repair.

Spellman Worldwide Service Centers

For a complete listing of **Spellman's** Global Service facilities please go to:
<http://www.spellmanhv.com/customerservice/service.asp>

THIS INFORMATION CONTAINED HEREIN IS PROPRIETARY TO SPELLMAN HIGH VOLTAGE ELECTRONICS CORP. AND IS TO BE USED ONLY FOR THE PURPOSES INTENDED AND IS NOT TO BE REPRODUCED EITHER IN WHOLE OR PART WITHOUT THE EXPRESS WRITTEN PERMISSION OF SPELLMAN HIGH VOLTAGE ELECTRONICS CORP.

SYM	DESCRIPTION	QTY
-----	-------------	-----

REVISIONS				APPROVED		
LTR	DESCRIPTION	DATE	MECH DESIGN	PROJ ENG	QUALITY	MFG ENG
A	RELEASED PER EDR 3965	8/24/95	M.M.	UdD	K.K.	J.J.
A1	REVISED PER ECN NO. 9695, CORRECT, DWG.	7/3/96	M.M.	J.P.	K.K.	J.J.
B	REVISED PER ECN NO. 9725	8/22/96	N/A	J.P.	M.P.	J.J.

D

D

C

C

B

B

A

A

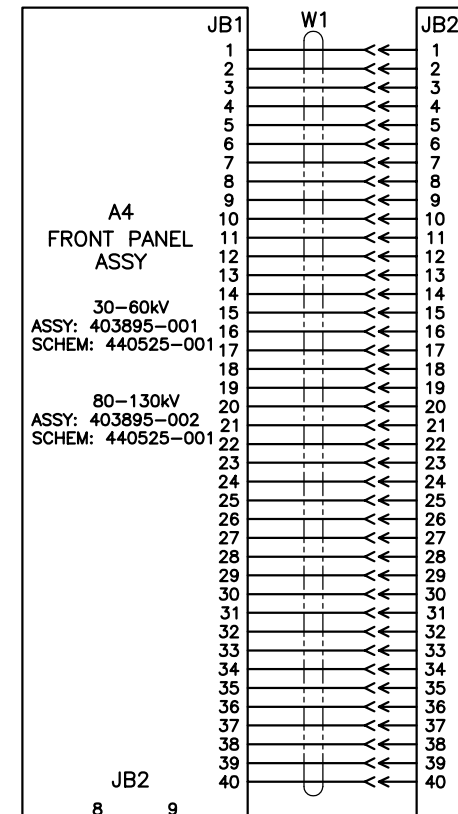
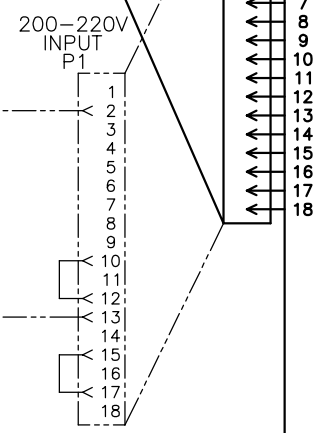
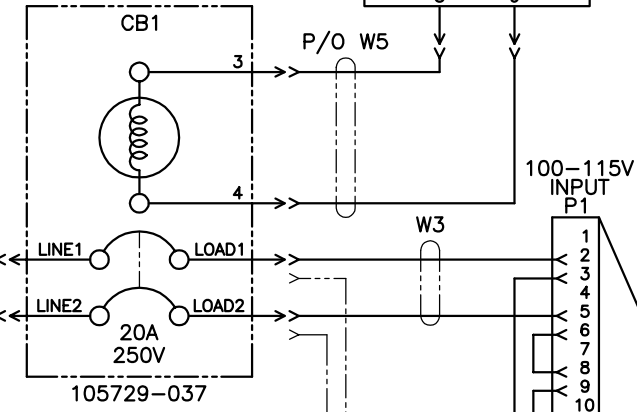
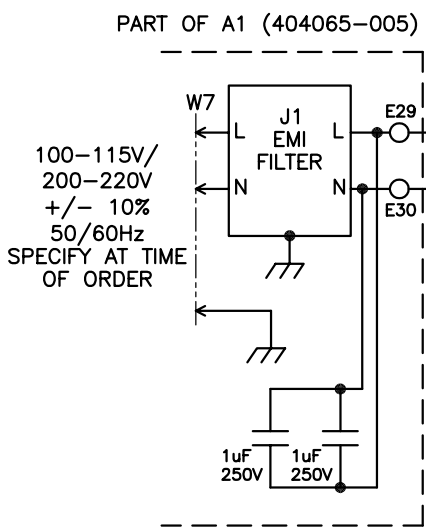

A1
CONTROL/POWER
PWB ASSY

30-60kV
ASSY: 404065-005
SCHEM: 440570-002

80-130kV
ASSY: 404065-006
SCHEM: 440570-002

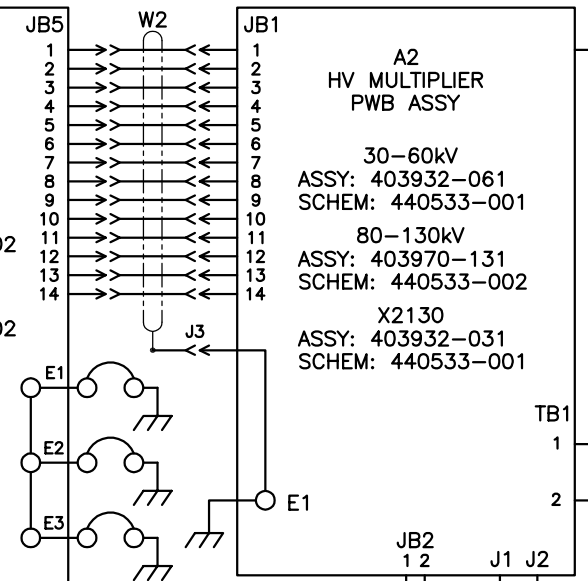

A2
HV MULTIPLIER
PWB ASSY

30-60kV
ASSY: 403932-061
SCHEM: 440533-001

80-130kV
ASSY: 403970-131
SCHEM: 440533-002

X2130
ASSY: 403932-031
SCHEM: 440533-001

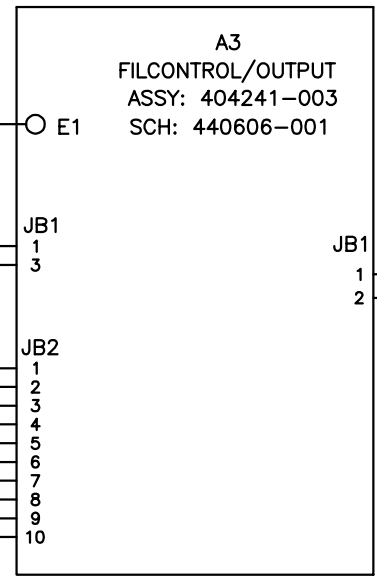
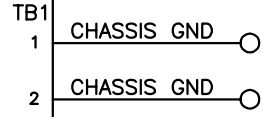
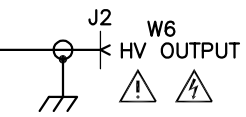

9A, 3.5VDC/
3A, 3.5VDC
SPECIFY AT TIME
OF ORDER

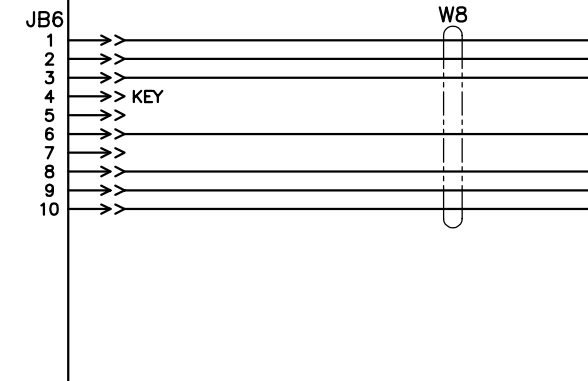
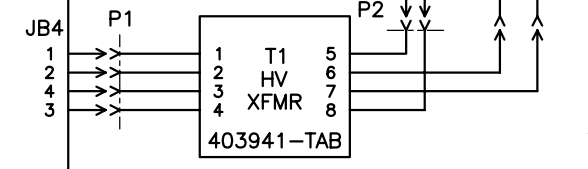

- 1 PS COM
- 2 RMT INHIBIT
- 3 EXTERNAL INTLK
- 4 EXTERNAL INTLK RE
- 5 mA TP
- 6 kV TP
- 7 +10V I/O
- 8 mA PROG
- 9 LCL mA PROG OUT
- 10 kV PROG
- 11 LCL kV PROG OUT
- 12 PWR TP
- 13 RMT PWR PROG
- 14 LCL HV OFF OUT
- 15 HV OFF
- 16 RMT HV ON
- 17 RMT HV OFF IND
- 18 LCL HV ON IND
- 19 RMT V MODE
- 20 RMT I MODE
- 21 RMT P MODE
- 22 RMT PS FAULT
- 23 +15V I/O
- 24 PS COMMON
- 25 I/O SHEILD

440530-009		XLG
PART NO.	NEXT ASSY	USED ON
APPLICATION		

UNLESS OTHERWISE SPECIFIED DIMENSIONS ARE IN INCHES TOLERANCES ARE:		
FRACTIONS	DECIMALS	ANGLES
±	.XX ±	±
	.XXX	

APPROVALS		
DRAWN	BY	DATE
	Mark Mauro	8/18/95
CHECKED	N/A	N/A
MECH. DESIGN	Mark Mauro	8/18/95
PROJ. ENG.	UdD	8/24/95
Q.A.	K.K.	8/29/95
MFG. ENG.	J.J.	8/30/95

SPELLMAN HIGH VOLTAGE ELECTRONICS CORPORATION
7 FAIRCHILD AVENUE, PLAINVIEW, NEW YORK 11803

SYSTEM INTERCONNECT
XLG 30-130kV

SIZE	CODE IDENT NO.	DRAWING NO.	REV
D	10610	440530-009	B

SCALE: NONE FILE# SHEET 1 OF 1

8

7

6

5

4

3

2

1

THIS INFORMATION CONTAINED HEREIN IS PROPRIETARY TO SPELLMAN HIGH VOLTAGE ELECTRONICS CORP. AND IS NOT TO BE REPRODUCED EITHER IN WHOLE OR PART WITHOUT THE EXPRESS WRITTEN PERMISSION OF SPELLMAN HIGH VOLTAGE ELECTRONICS CORP.

REVISIONS			APPROVED		
LTR	DESCRIPTION	DATE	MECH ENG	PROJ ENG	QUALITY
A	RELEASED PER EDR 3349	8/16/93	M.H.	C.S.	KK,TS
B	REVISED PER ECN 7718, A/W SILKSCREEN CHANGE	1/19/94	M.H.	C.S.	KK,TS
B1	REVISED PER ECN 7871	4/6/94	M.H.	C.S.	KK,TS
B2	REVISED PER ECN 9847	9/1/96	MY	AV	KK,TS
B3	REVISED PER ECN 10344	3/19/97	AP	CB	KK,LB
C	REVISED PER ECN 12525				

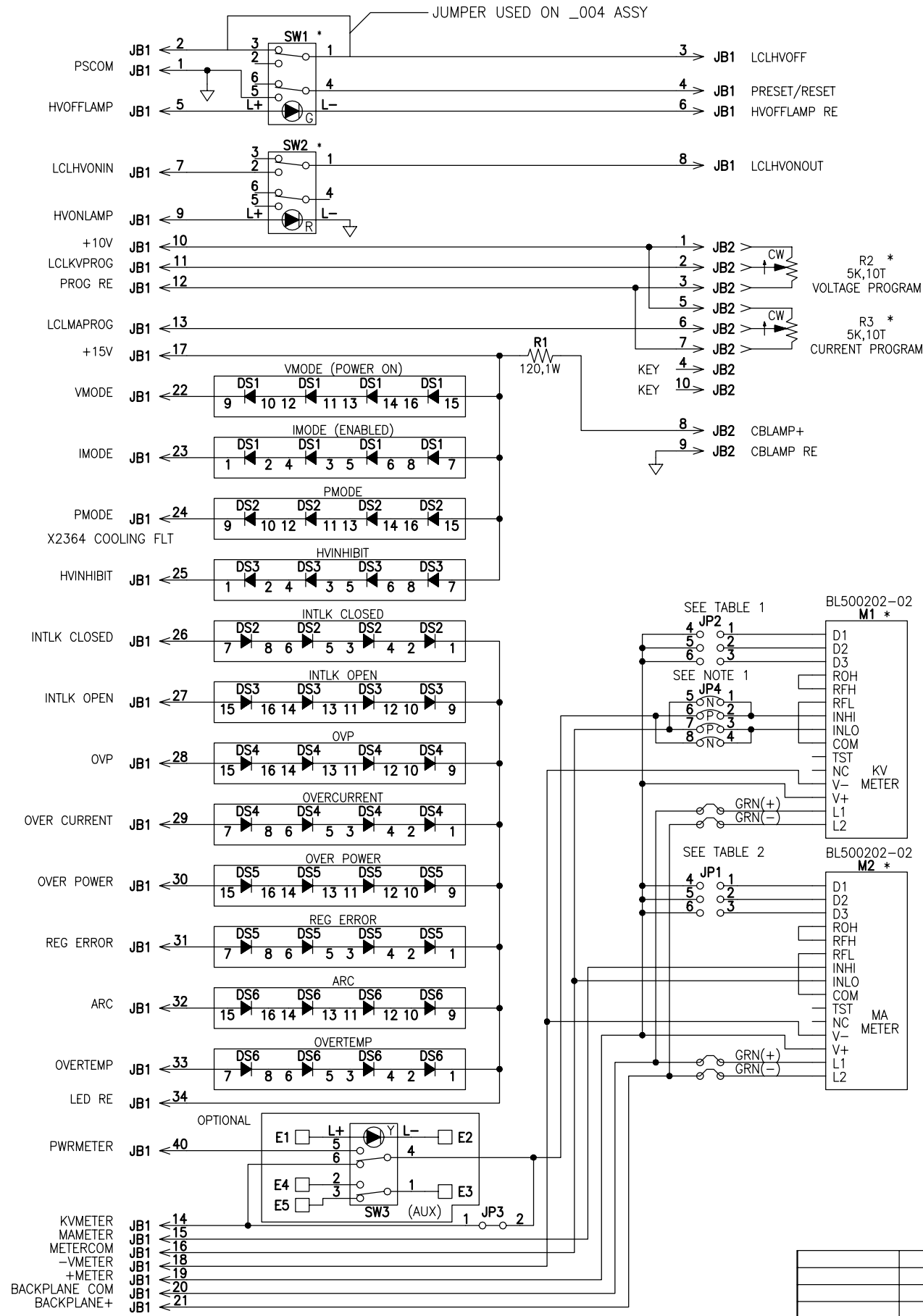

NOTES:
1. FOR POSITIVE METER POLARITY
JUMP JP4,2-6,3-7.
FOR NEGATIVE METER POLARITY
JUMP JP4,1-5,4-8.
2. *INDICATES NOT USED ON _004 ASSY

KV	JP2
<2	1-4
>2-<20	2-5
>20	3-6
-	OPEN

MA	JP1
<2	1-4
>2-<20	2-5
>2-<200	3-6
>200	OPEN

- JB1 ← 35 SPARE
- JB1 ← 36 SPARE
- JB1 ← 37 SPARE
- JB1 ← 38 SPARE
- JB1 ← 39 SPARE

- KVMETER JB1 ← 14
- MAMETER JB1 ← 15
- METERCOM JB1 ← 16
- VMETER JB1 ← 18
- +METER JB1 ← 19
- BACKPLANE COM JB1 ← 20
- BACKPLANE+ JB1 ← 21

UNLESS OTHERWISE SPECIFIED DIMENSIONS ARE IN INCHES TOLERANCES ARE: FRACTIONS ± .005 DECIMALS ± .001 ANGLES ± .001		APPROVALS		 HIGH VOLTAGE ELECTRONICS CORPORATION 7 FAIRCHILD AVENUE, PLAINFIELD, NEW YORK 11803
MATERIAL		BY	DATE	
FINISH		DRAWN	2/10/93	SCHEMATIC DIAGRAM FRONT PANEL ASSEMBLY SL SERIES
440525-001 403895-001 SL		CHECKED	N/A N/A	
PART NO. NEXT ASSY USED ON		DESIGN	S. POLI 8/16/93	
APPLICATION		MECH. ENG.	M.H. 8/16/93	
DO NOT SCALE DRAWING		PROJ. ENG.	C.S. 8/16/93	
DO NOT SCALE DRAWING		QA	K.K. 8/16/93	SIZE: D CODE IDENT NO. 10610 DRAWING NO. 440525-001 SCALE: NONE FILE# 440/525001C.SCH SHEET 1 OF 1
DO NOT SCALE DRAWING		MFG. ENG.	T.S. 8/16/93	BREAK ALL SHARP EDGES & CORNERS

THIS INFORMATION CONTAINED HEREIN IS PROPRIETARY TO SPELLMAN HIGH VOLTAGE ELECTRONICS CORP. AND IS TO BE USED ONLY FOR THE PURPOSES INTENDED AND IS NOT TO BE REPRODUCED EITHER IN WHOLE OR PART WITHOUT THE EXPRESS WRITTEN PERMISSION OF SPELLMAN HIGH VOLTAGE ELECTRONICS CORP.

REVISIONS		APPROVED	
LTR	DESCRIPTION	DATE	DESIGN
B	RELEASED PER EDR 3444	1/15/94	J.P.
B1	REVISED PER EGN 7935	6/20/94	J.P.
C	REVISED PER EGN 8221	10/17/94	J.P.
D	REVISED PER EGN 8998	7/23/95	J.P.
D1	REVISED PER EGN 9111	8/24/95	J.P.
D2	REVISED PER EGN 9204	10/11/95	J.P.
E	REVISED PER EGN 9725	3/18/96	J.P.
E1	REVISED PER EGN 9931	10/31/96	J.P.
E2	REVISED PER EGN 10853	9/25/97	J.P.
E3	REVISED PER EGN 10957	10/24/97	J.P.
E4	REVISED PER EGN 10979	10/24/97	J.P.
E5	REVISED PER EGN 1119	12/29/97	J.P.
E6	REVISED PER EGN 11361	3/20/98	J.P.
F	REVISED PER EGN 11516	5/14/98	J.P.
F1	REVISED PER EGN 12337	4/9/99	J.P.
F2	REVISED PER EGN 12378	5/28/99	J.P.
F3	REVISED PER EGN 12861	7/8/99	J.P.
F4	REVISED PER EGN 12801	12/22/99	J.P.
F5	REVISED PER EGN 16055	7/10/03	J.P.

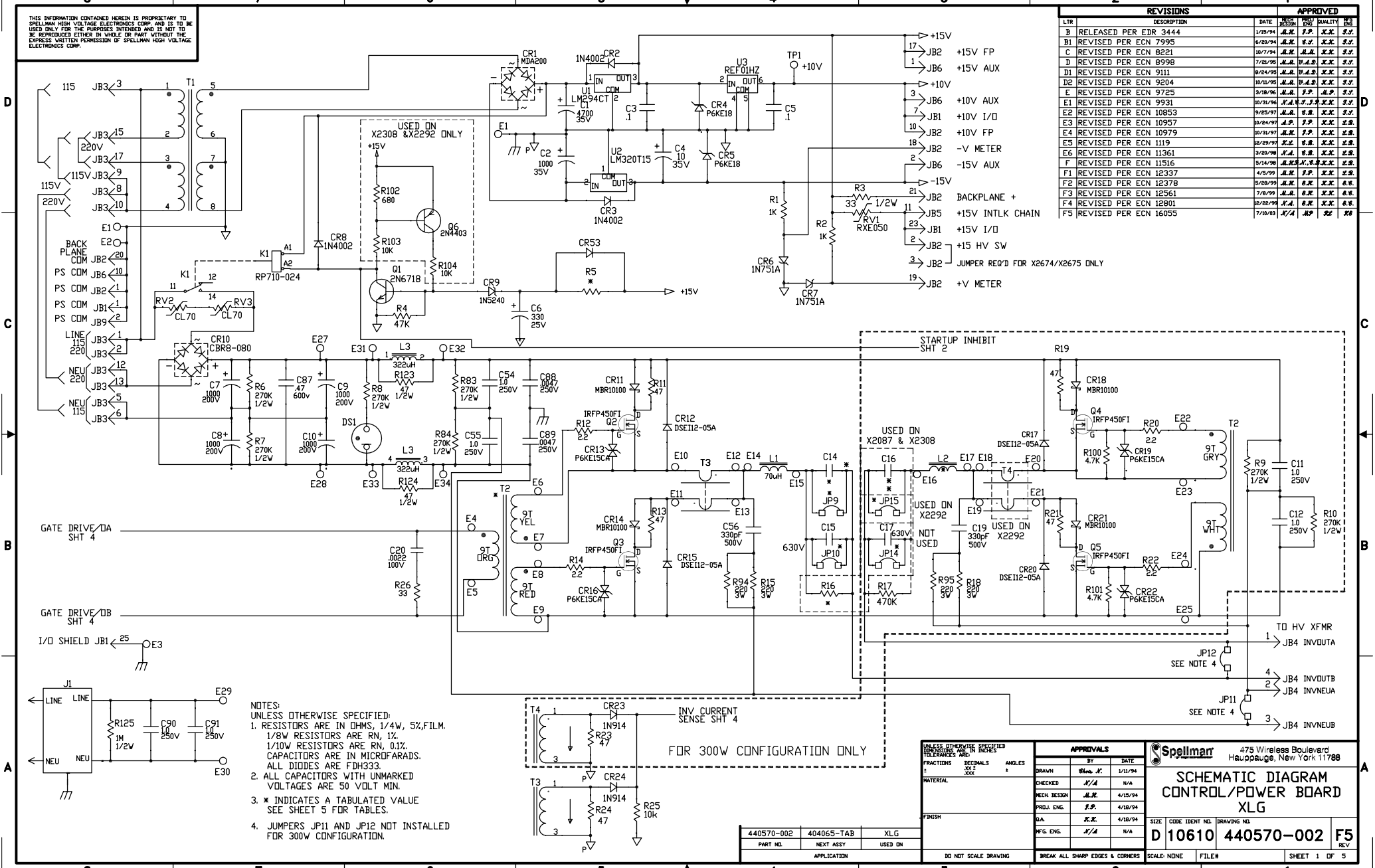

- NOTES:
UNLESS OTHERWISE SPECIFIED:
1. RESISTORS ARE IN OHMS, 1/4W, 5%, FILM.
1/8W RESISTORS ARE RN, 1%.
1/10W RESISTORS ARE RN, 0.1%.
CAPACITORS ARE IN MICROFARADS.
ALL DIODES ARE FDH333.
2. ALL CAPACITORS WITH UNMARKED VOLTAGES ARE 50 VOLT MIN.
3. * INDICATES A TABULATED VALUE SEE SHEET 5 FOR TABLES.
4. JUMPERS JP11 AND JP12 NOT INSTALLED FOR 300W CONFIGURATION.

UNLESS OTHERWISE SPECIFIED TOLERANCES ARE:	
FRACTIONS	DECIMALS
XX	XX
XX	XX
XX	XX

APPROVALS		
BY	DATE	
DRAWN	1/11/94	
CHECKED	X/A	N/A
MECH DESIGN	J.P.	4/15/94
PROJ. ENG.	J.P.	4/18/94
QA	X/X	4/18/94
MFG. ENG.	X/A	N/A

Spellman 475 Wireless Boulevard
Hauppauge, New York 11788

**SCHEMATIC DIAGRAM
CONTROL/POWER BOARD
XLG**

440570-002	404065-TAB	XLG
PART NO.	NEXT ASSY	USED DN
	APPLICATION	

DO NOT SCALE DRAWING	BREAK ALL SHARP EDGES & CORNERS	SCALE: NONE	FILE#
SIZE: D	CODE IDENT NO: 10610	DRAWING NO: 440570-002	F5
			REV

THIS INFORMATION CONTAINED HEREIN IS PROPRIETARY TO SPELLMAN HIGH VOLTAGE ELECTRONICS CORP. AND IS TO BE USED ONLY FOR THE PURPOSES INTENDED AND IS NOT TO BE REPRODUCED EITHER IN WHOLE OR PART WITHOUT THE EXPRESS WRITTEN PERMISSION OF SPELLMAN HIGH VOLTAGE ELECTRONICS CORP.

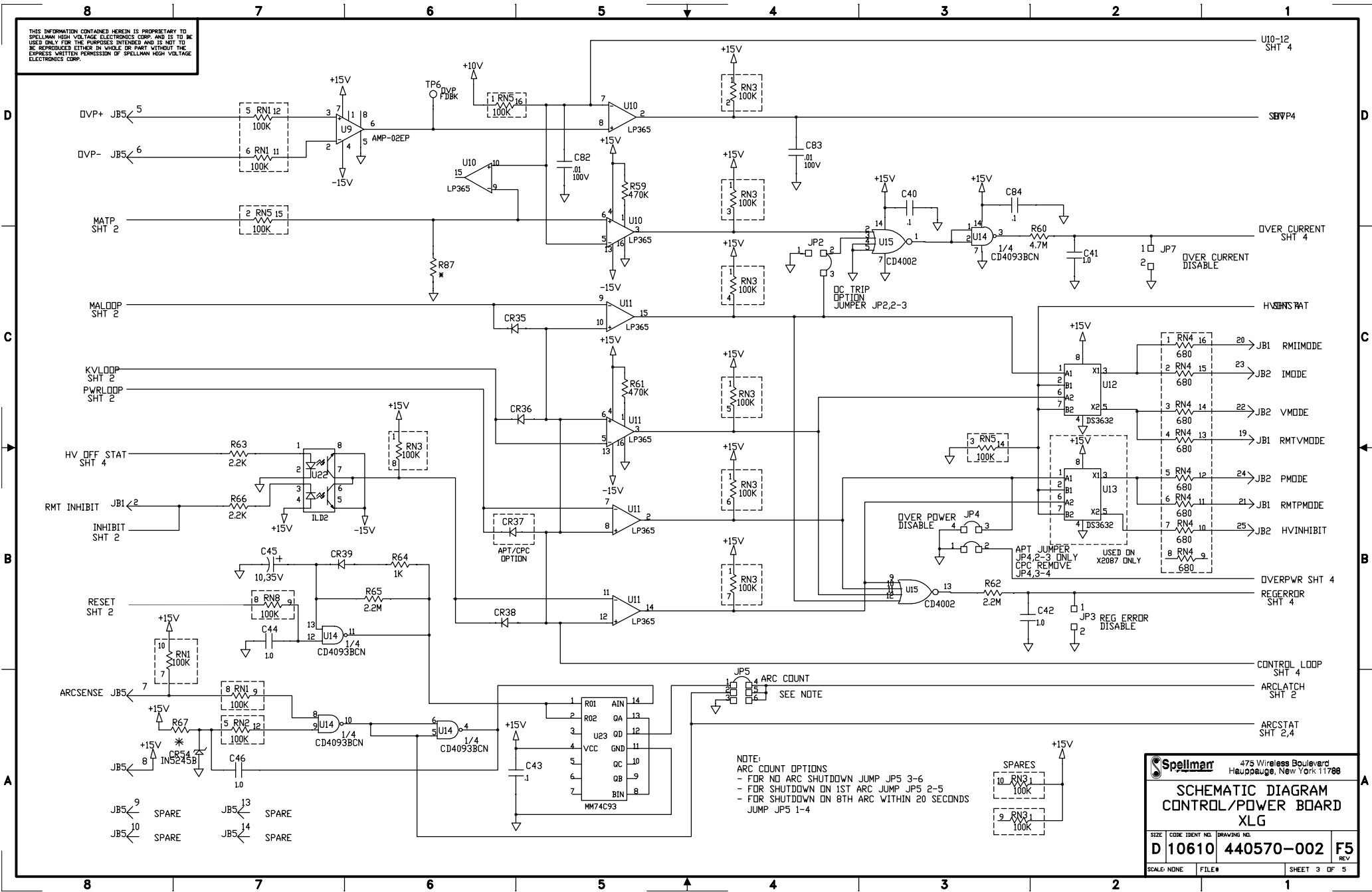

NOTE:
 ARC COUNT OPTIONS
 - FDR NO ARC SHUTDOWN JUMP JPS 3-6
 - FDR SHUTDOWN ON 1ST ARC JUMP JPS 2-5
 - FDR SHUTDOWN ON 8TH ARC WITHIN 20 SECONDS
 JUMP JPS 1-4

Spellman 475 Wireless Boulevard
 Hauppauge, New York 11788

**SCHEMATIC DIAGRAM
 CONTROL/POWER BOARD
 XLG**

SIZE	CODE IDENT NO.	DRAWING NO.	REV
D	10610	440570-002	F5
SCALE: NONE	FILE#	SHEET 3 OF 5	

THIS INFORMATION CONTAINED HEREIN IS PROPRIETARY TO SPELLMAN HIGH VOLTAGE ELECTRONICS CORP. AND IS TO BE USED ONLY FOR THE PURPOSES INTENDED AND IS NOT TO BE REPRODUCED EITHER IN WHOLE OR PART WITHOUT THE EXPRESS WRITTEN PERMISSION OF SPELLMAN HIGH VOLTAGE ELECTRONICS CORP.

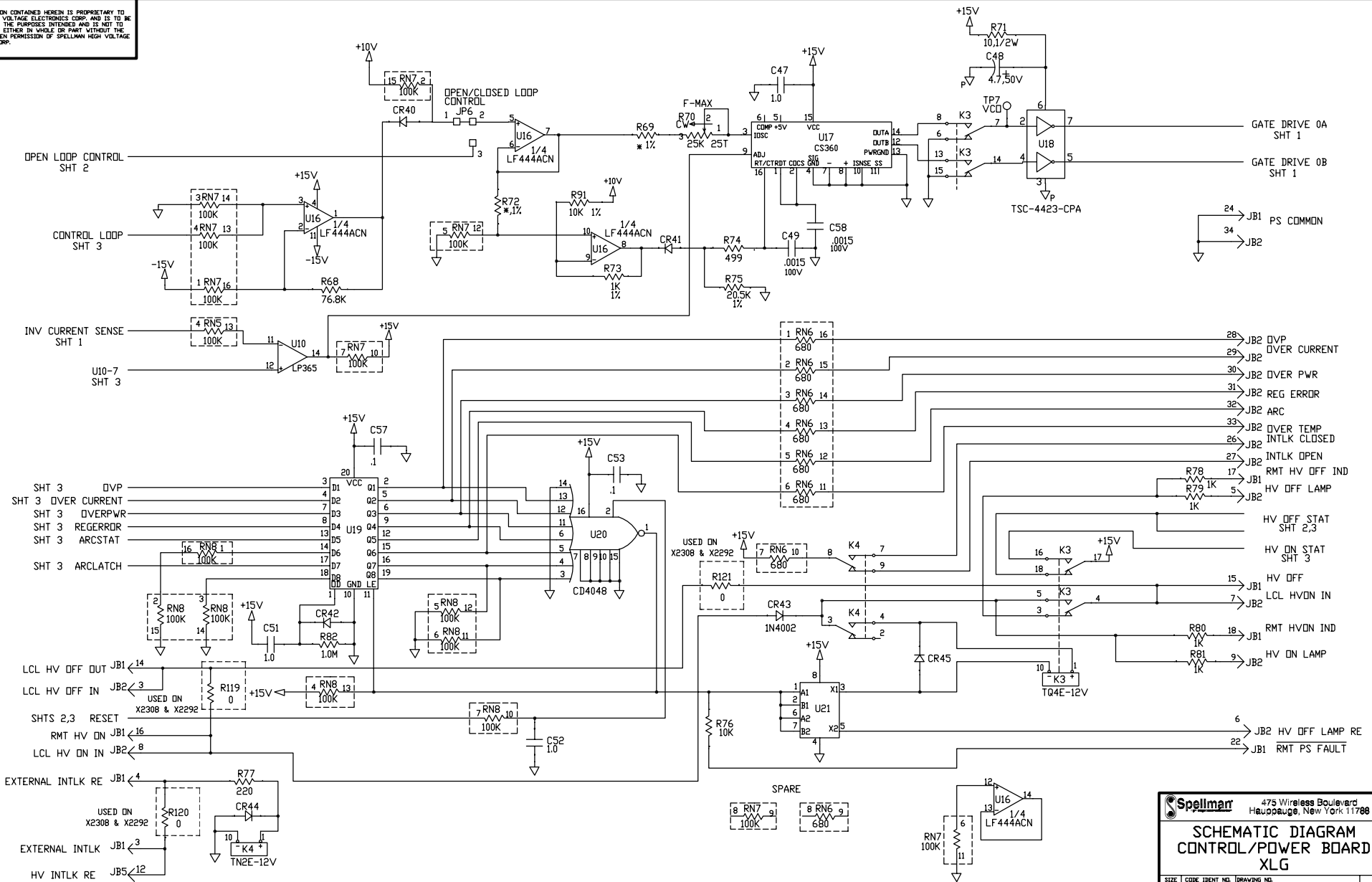

Spellman 475 Wireless Boulevard
Hauppauge, New York 11788

**SCHEMATIC DIAGRAM
CONTROL/POWER BOARD
XLG**

SIZE	CODE IDENT NO.	DRAWING NO.	REV
D	10610	440570-002	F5
SCALE: NONE	FILE#	SHEET	4 OF 5

THIS INFORMATION CONTAINED HEREIN IS PROPRIETARY TO SPELLMAN HIGH VOLTAGE ELECTRONICS CORP. AND IS TO BE USED ONLY FOR THE PURPOSES INTENDED AND IS NOT TO BE REPRODUCED EITHER IN WHOLE OR PART WITHOUT THE EXPRESS WRITTEN PERMISSION OF SPELLMAN HIGH VOLTAGE ELECTRONICS CORP.

mA	R34	mA	R34
300	174K	1.66	26.7K
150	30.1K	1.5	30.1K
100	49.9K	1.25	38.3K
75	68.1K	1.2	40.2K
60	86.6K	1.15	42.2K
50	105K	1	49.9K
37.5	140K	.86	59K
30	174K	.75	68.1K
25	210K	.67	76.8K
20	22.1K	.6	86.6K
18.75	23.2K	.5	105K
15	30.1K	.46	113K
10	49.9K	.43	121K
8	63.4K	.38	140K
7.5	68.1K	.33	165K
6	86.6K	.30	174K
5	105K	.25	210K
4.28	121K	.23	232K
4	133K	.20	22.1K
3.75	140K	.17	26.7K
3.3	165K	.14	33.2K
3	174K	.13	37.4K
2.5	210K	.10	49.9K
2.3	232K	.083	59K
2.14	20.0K	.076	68.1K
2	22.1K		
1.88	23.2K		

kV	R42
1	49.9K
2	22.1K
3	174K
6	86.6K
8	63.4K
10	49.9K
15	30.1K
20	22.1K
30	174K
35	150K
40	133K
50	105K
60	86.6K
70	73.2K
80	63.4K
100	49.9K
120	40.2K
130	37.4K

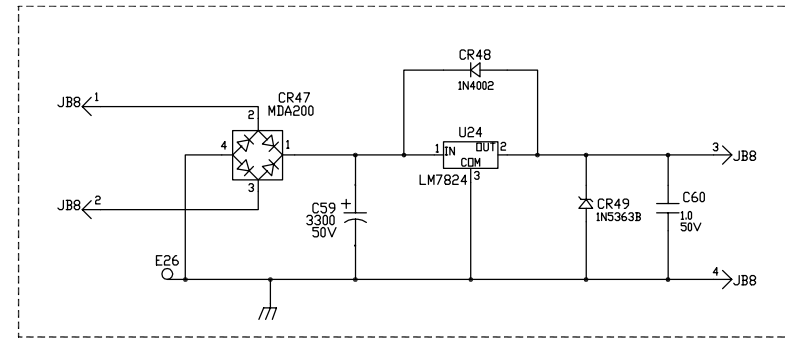

USED ON X2146 ONLY

*X' NO.	R5	R51	R110	C36	L2	T2	C26	R30	R33	R41	R87	R72	C14	C16	R16	JP9	JP10	JP14	JP15	R28	R39	R69	R99	CR50	R105	R67	CR54
X2087	3.3K	4.7MEG	-	1.0	120uH	303174-001	.0056	10K	49.9K	20K	470K	100K	-	.0056, 800V	-	IN	IN	OUT	OUT	12M	10K	59K	86.6K	-	0.0		
X2308	133K	12MEG	10MEG	100	120uH	303174-001	.0056	10K	49.9K	20K	470K	100K	-	.0056, 800V	-	IN	IN	OUT	OUT	4.7M	10K	59K	86.6K	IN	0.0		
X2292	133K	12MEG	10MEG	100	70uH	303174-002	.0056	10K	49.9K	20K	470K	100K	-	-	-	IN	IN	OUT	IN	18M	10K	59K	86.6K	IN	0.0	470K	NOT USED
XLG150V	3.3K	4.7MEG	-	1.0	-	303174-001	.0056	10K	49.9K	20K	470K	100K	-	-	-	IN	IN	OUT	OUT	12M	10K	59K	86.6K	-	0.0		
XLG300V	3.3K	4.7MEG	-	1.0	35uH	303174-002	.0056	10K	49.9K	20K	470K	100K	-	-	-	IN	IN	IN	OUT	12M	10K	59K	86.6K	-	0.0		
X2674/5	3.3K	4.7MEG	-	0.01	35uH	303174-002	0.01	24.9K	10.0K	24.9K	1MEG	150K	.22, 630V	.22, 630V	1/2W470K	OUT	OUT	OUT	OUT	12M	10K	59K	-	-	0.0		
X2516	3.3K	1.2MEG	-	.10	-	303174-001	.22	-	24.9K	24.9K	-	133K	0.116KV	-	1/2W470K	OUT	OUT	OUT	OUT	47M	4.99K	71.5K	-	-	OUT	301K	1N5245B
X2895	3.3K	127K	N/U	1.0	70uH	303174-002	.22	N/U	24.9K	49.9K	1.65M	174K	N/U	N/U	N/U	IN	IN	IN	IN	15M	2.00K	49.9K	N/U	N/U	N/U	332K	1N5245B

Spellman 475 Wireless Boulevard
Hauppauge, New York 11788

**SCHEMATIC DIAGRAM
CONTROL/POWER BOARD
XLG**

SIZE	CODE	IDENT NO.	DRAWING NO.	REV
D	10610	440570-002	F5	

SCALE: NONE FILE# SHEET 5 OF 5

THIS INFORMATION CONTAINED HEREIN IS PROPRIETARY TO SPELLMAN HIGH VOLTAGE ELECTRONICS CORP. AND IS NOT TO BE USED ONLY FOR THE PURPOSES INTENDED AND IS NOT TO BE REPRODUCED EITHER IN WHOLE OR PART WITHOUT THE EXPRESS WRITTEN PERMISSION OF SPELLMAN HIGH VOLTAGE ELECTRONICS CORP.

DESCRIPTION OF HOLES

HOLE SIZES APPLY TO INSTALLATION SIZE OF HARDWARE, IF APPLICABLE

SYM	DESCRIPTION	QTY
-----	-------------	-----

REVISIONS						APPROVED	
LR	DESCRIPTION	DATE	DESIGN	PROF	QUALITY	BY	DATE
E15	REVISED PER ECN NO. 21791	8/29/98	J/A	J/P	J/P	J/P	J/P
E16	REVISED PER ECN NO. 21977	8/29/98	J/A	J/P	J/P	J/P	J/P
E17	REVISED PER ECN NO. 22581	2/12/99	J/A	J/P	J/P	J/P	J/P
E18	REVISED PER ECN NO. 23534	10/22/99	J/A	J/P	J/P	J/P	J/P

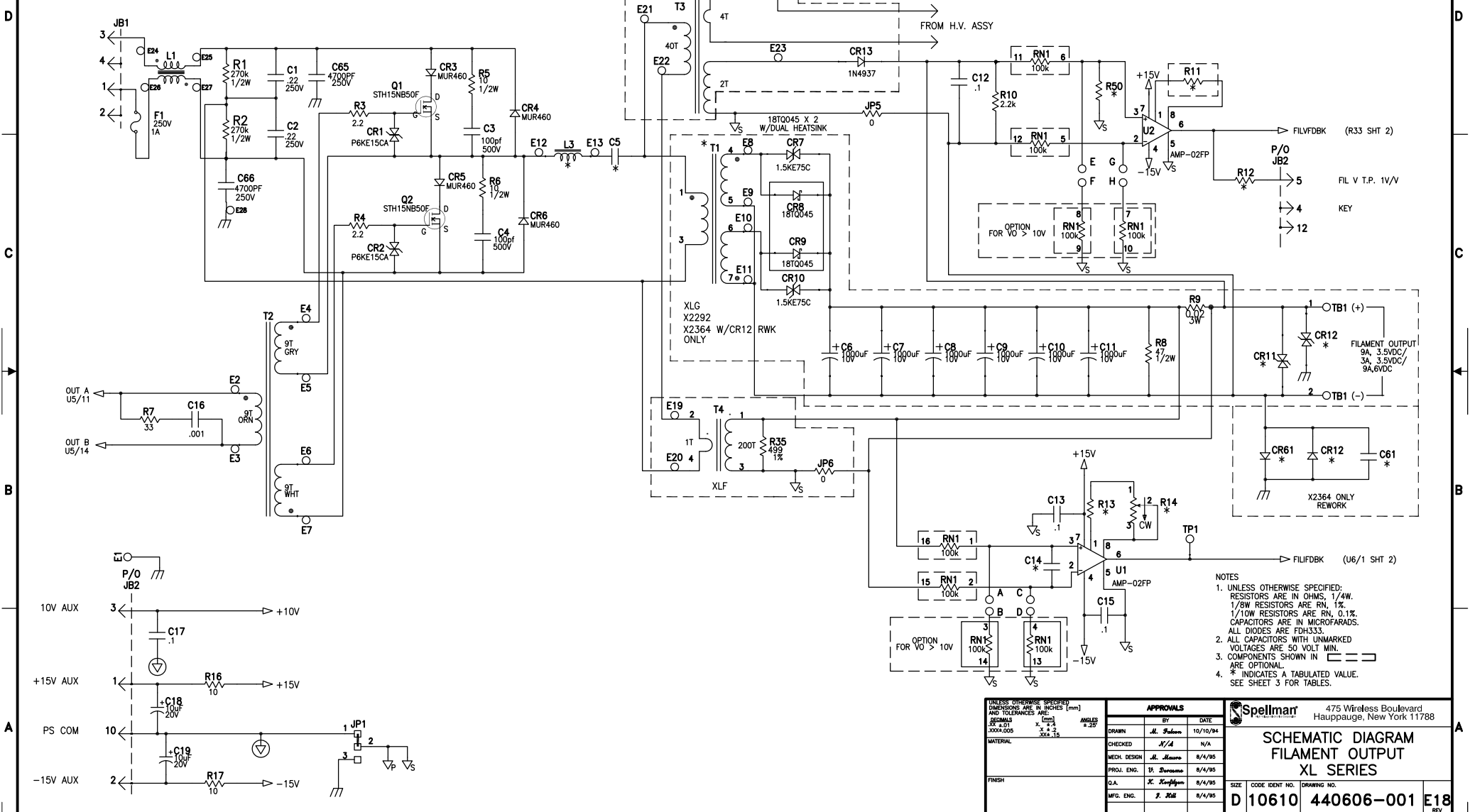

- NOTES
- UNLESS OTHERWISE SPECIFIED: RESISTORS ARE IN OHMS, 1/4W. 1/8W RESISTORS ARE RN, 1%. 1/10W RESISTORS ARE RN, 0.1%. CAPACITORS ARE IN MICROFARADS. ALL DIODES ARE FDH333.
 - ALL CAPACITORS WITH UNMARKED VOLTAGES ARE 50 VOLT MIN.
 - COMPONENTS SHOWN IN ARE OPTIONAL.
 - * INDICATES A TABULATED VALUE. SEE SHEET 3 FOR TABLES.

UNLESS OTHERWISE SPECIFIED DIMENSIONS ARE IN INCHES [mm]		APPROVALS		Spellman	
FORMATS	ANGLES	BY	DATE	475 Wireless Boulevard Hauppauge, New York 11788	
ASME Y14.5	ASME Y14.5	DRAWN	10/10/94	SCHMATIC DIAGRAM FILAMENT OUTPUT XL SERIES	
3004-005	3004-005	CHECKED	N/A		
		MECH. DESIGN	8/4/95		
		PROJ. ENGR.	8/4/95		
		Q.A.	8/4/95		
		MFG. ENGR.	8/4/95	SIZE: D 10610 CODE IDENT. NO.: 440606-001 DRAWING NO.: E18	
DO NOT SCALE DRAWING		BREAK ALL SHARP EDGES & CORNERS		SCALE: NONE THIRD ANGLE PROJECTION SHEET 1 OF 4	

THIS INFORMATION CONTAINED HEREIN IS PROPRIETARY TO SPELLMAN HIGH VOLTAGE ELECTRONICS CORP. AND IS TO BE USED ONLY FOR THE PURPOSES INTENDED AND IS NOT TO BE REPRODUCED EITHER IN WHOLE OR PART WITHOUT THE EXPRESS WRITTEN PERMISSION OF SPELLMAN HIGH VOLTAGE ELECTRONICS CORP.

TABLE 1

R41	
mA	VALUE
30	365,3W,WW
24	464,3W,WW
20	549,1W,WW
15	750,1W,WW
12	931,1W,WW
10	1.13K,1W,WW
7.5	1.5K,1W,WW
6	1.87K,1W,WW
5	2.32K,1/4W,1%
4	2.87K,1/4W,1%
3.75	3.09K,1/4W,1%
3.33	3.48K,1/4W,1%
3	3.92K, 1%
2.5	4.87K, 1%
2	6.19K, 1%
1.67	7.5K, 1%
1.25	10.2K, 1%
1	14K, 1%
.833	17.4K, 1%
40	274,1W,WW

TABLE 2

R36	
kV	VALUE
25	332K
30	274K
40	187K
50	105K
60	69.8K
60	95.3K

X2364 ONLY

TABLE 3

MODEL	ASSY NO.	C5	C14	C21	C23	C26	C30	C31	C32	C33	C36	C61	C62	C63	C64	C67	CR11	CR12	CR29	CR61	JP4	L3	R12	R13	R14	R18	R19	R24	R29	R30	R34	R38	R42	R45	R50	R51	R61	T1
X2130	404241-003	.0056	100pF	0.1	1.0	.01	1.0	.001 200V	.27 100V	.1 100V	N/A	N/A	N/A	N/A	N/A	N/A	1.5KE 75C	1.5KE 75C	IN	N/A	1-2	120uH	10K	1K	100	100K	2.2M	2.2M	10K	10K	100K	N/A	N/A	100K	N/A	OUT	N/A	4.0UH
X2274	404241-002	.047	N/A	.22	1.0	.22	4.7	.001 200V	.68	.068	1.0 100V	N/A	N/A	N/A	N/A	0.1	N/A	N/A	IN	N/A	2-3	28uH	10K	10K	10K	33.2K	2.2M	2.2M	2.94K	15K	100K	1K 1/2W	4.99K	10K	33.2K	22.1K	N/A	N/A
X2292	404241-001	.0056	100pF	0.1	100	.22	1.0	.001 200V	.27 100V	.1 100V	N/A	N/A	N/A	N/A	N/A	N/A	1.5KE 75C	1.5KE 75C	IN	N/A	1-2	120uH	10K	1K	100	100K	1.2M	402K	10K	10K	100K	N/A	N/A	10K	N/A	OUT	N/A	4.0UH
X2364	404241-004	.047	N/A	0.1	1.0	.01	4.7	0.1 50V	.27 100V	.1 100V	N/A	.47	1UF 50V	1UF 50V	68UF 10V	N/A	1.5KE 11CA	IN4002	IN	IN4002	1-2	200UH	N/A	1K	100	100K	7.5M	402K	10K	10K	210K	270 1/2W	N/A	100K	N/A	10K	470K	2.5mH
X2432	404241-005	.047	N/A	.22	1.0	.22	4.7	.001 200V	.68	.068	1.0 100V	N/A	N/A	N/A	N/A	0.1	N/A	N/A	OUT	N/A	2-3	28uH	10K	10K	10K	33.2K	2.2M	2.2M	2.94K	15K	100K	1K 1/2W	4.99K	10K	33.2K	22.1K 1/2	N/A	N/A
X2680	404241-006	.047	N/A	.22	1.0	.22	4.7	.001 200V	.1 100V	.1 100V	1.0 100V	N/A	N/A	N/A	N/A	0.1	N/A	N/A	OUT	N/A	2-3	28uH	10K	10K	10K	33.2K	2.2M	2.2M	2.94K	24.9K	100K	1K 1/2W	4.99K	10K	33.2K	22.1K 1/2	N/A	N/A
X2970	404241-003	.0056	100pF	0.1	1.0	.01	1.0	.001 200V	.27 100V	.1 100V	N/A	N/A	N/A	N/A	N/A	N/A	1.5KE 75C	1.5KE 75C	IN	N/A	1-2	120uH	10K	1K	100	100K	2.2M	2.2M	10K	10K	100K	N/A	N/A	100K	N/A	OUT	N/A	4.0UH
X3111	404241-007	.047	N/A	.47	100	.22	1.0	.001 200V	.68	.068	1.0 100V	N/A	N/A	N/A	N/A	0.1	N/A	N/A	IN	N/A	2-3	28uH	10K	10K	10K	46.9K	1.5M	1M	2.94K	15K	100K	1K 1/2W	4.99K	10K	33.2K	22.1K	N/A	N/A
X3145	404241-004	.047	N/A	0.1	1.0	.01	4.7	0.1 50V	.27 100V	.1 100V	N/A	.47	1UF 50V	1UF 50V	68UF 10V	N/A	1.5KE 11CA	IN4002	IN	IN4002	1-2	200UH	N/A	1K	100	100K	7.5M	402K	10K	10K	210K	270 1/2W	N/A	100K	N/A	10K	470K	2.5mH
X3222	404241-002	.047	N/A	.22	1.0	.22	4.7	.001 200V	.68	.068	1.0 100V	N/A	N/A	N/A	N/A	0.1	N/A	N/A	IN	N/A	2-3	28uH	10K	10K	10K	33.2K	2.2M	2.2M	2.94K	15K	100K	1K 1/2W	4.99K	10K	33.2K	22.1K	N/A	N/A
X3782	404241-008	.047	N/A	.22	1.0	.22	4.7	.001 200V	.68	.068	1.0 100V	N/A	N/A	1UF 50V	N/A	0.1	N/A	N/A	IN	N/A	2-3	28uH	10K	10K	10K	33.2K	2.2M	2.2M	2.94K	15K	100K	1K 1/2W	4.99K	10K	33.2K	22.1K	N/A	N/A
x4063	404241-008	.047	N/A	.22	1.0	.22	4.7	.001 200V	.68	.068	1.0 100V	N/A	N/A	1UF 50V	N/A	0.1	N/A	N/A	IN	N/A	2-3	28uH	10K	10K	10K	33.2K	2.2M	2.2M	2.94K	15K	100K	1K 1/2W	4.99K	10K	33.2K	22.1K	N/A	N/A
XLF	404241-002	.047	N/A	.22	1.0	.22	4.7	.001 200V	.68	.068	1.0 100V	N/A	N/A	N/A	N/A	0.1	N/A	N/A	IN	N/A	2-3	28uH	10K	10K	10K	33.2K	2.2M	2.2M	2.94K	15K	100K	1K 1/2W	4.99K	10K	33.2K	22.1K	N/A	N/A
XLG	404241-003	.0056	100pF	0.1	1.0	.01	1.0	.001 200V	.27 100V	.1 100V	N/A	N/A	N/A	N/A	N/A	N/A	1.5KE 75C	1.5KE 75C	IN	N/A	1-2	120uH	10K	1K	100	100K	2.2M	2.2M	10K	10K	100K	N/A	N/A	100K	N/A	OUT	N/A	4.0UH

Spellman 475 Wireless Boulevard
Hauppauge, New York 11788

**SCHMATIC DIAGRAM
FILAMENT OUTPUT
XL SERIES**

SIZE CODE IDENT NO. DRAWING NO.
D 10610 440606-001 E18

SCALE: NONE THIRD ANGLE PROJECTION SHEET 4 OF 4